

LS 92

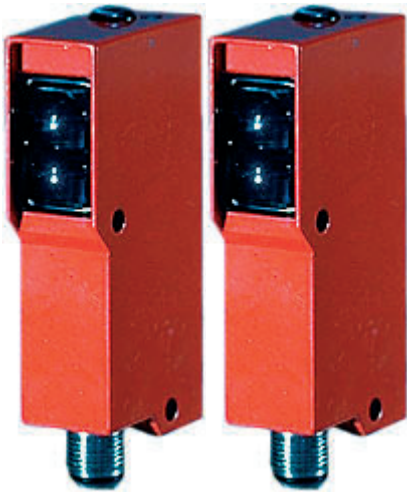

Protective throughbeam photoelectric sensor

! Safety note:

- The protective throughbeam photoelectric sensor is a contactless active protective device in connection with a safety-relevant control system, in which the cyclical testing of transmitter and receiver is carried out according to EN 61496-1, category 2 (testing).
- The power supply unit used to operate the photoelectric sensor must be able to compensate for changes and interruptions of the supply voltage acc. to EN 61496-1.
Minimum blackening object: $\varnothing 13\text{mm}$.

Accessories

(available separately)

- Mounting system (BT 92, UMS 1)
- M12 connectors (KD ...)
- Ready-made cables (KB ...)
- Test-monitoring unit:
 - TNT 32 (Part No. 500 20476)
 - TNT 33 (Part No. 500 28158)
 - TNT 34 (Part No. 500 81023)
 - TNT 35 (Part No. 500 33058)
 - TMC 66 (Part No. 500 82121)



Leuze lumiflex GmbH + Co.KG
 Liebigstraße 4
 D-82256 Fürstentfeldbruck, Germany
 Tel: +49 8141 5350-0
 Fax: +49 8141 5350-190
 E-Mail: lumiflex@leuze.de
 www.leuze.com

Features

- Activation input for testing and interlinking
- Compact construction with robust diecast zinc housing and glass optics for protection against environmental influences
- Light or dark switching by reversing the polarity of the operating voltage
- Electrical connection with M12 connector or 6-pin standard plug

Electrical Connection

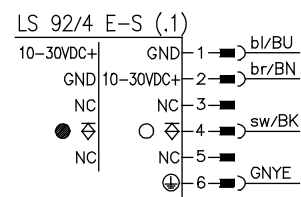
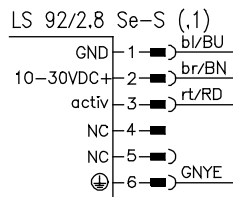
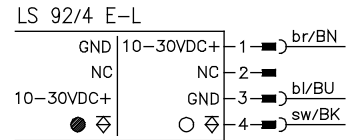
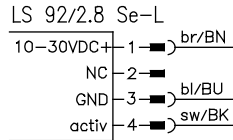

Dimensional Drawing

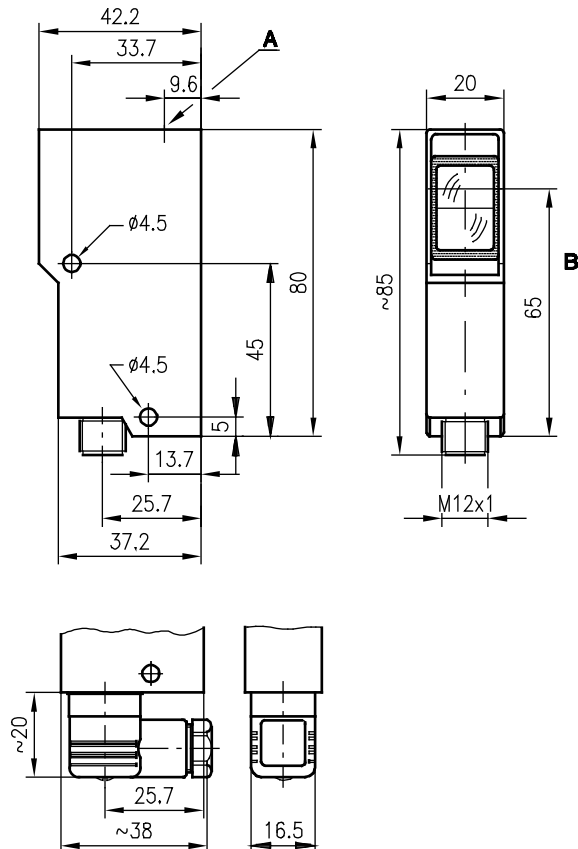

LS 92/2.8 Se-S
 LS 92/4 E-S
 LS 92/4 E-S.1
 LS 92/2.8 Se-S.1

A Indicator diode

B Optical axis

Technical Data

Optical data	
Typ. operating range limit ¹⁾	0 ... 16m
Operating range ²⁾	0 ... 12m
Light source	LED (modulated light)
Wavelength	880nm
Timing	
Switching frequency	200Hz
Response time	2,5ms
Delay before start-up	≤ 100ms
Electrical data	
Operating voltage U_B	10 ... 30VDC (incl. residual ripple)
Residual ripple	≤ 15% of U_B
Bias current	≤ 35mA
Switching output	PNP transistor output
Function characteristics	Light or dark switching (by reversing the polarity of U_B)
Signal voltage high/low	≥ ($U_B - 2V$) / ≤ 2V
Output current	max. 100mA
Indicators	
Receiver	
LED yellow	light path free
LED yellow flashing	light path free, no performance reserve
Transmitter	
LED yellow	transmitter ON
Mechanical data	
Housing	diecast zinc
Optics	glass
Weight	140g
Connection type	M12 connector or 6-pin standard plug
Environmental data	
Ambient temp. (operation/storage)	-20°C ... +60°C / -30°C ... + 70°C
VDE safety class	I for S types
VDE safety class ³⁾	II for L types (M12 connector)
Protective circuit ⁴⁾	2,3
Protection class	IP67, IP 65 for all S types
Standards applied	IEC 60947-5-2
Options	
Activation input active	
Transmitter active/not active	≥ 8V / ≤ 2V or not connected
Activation/disable delay	≤ 1ms
Input resistance	4,7kΩ ± 10%

1) Typ. operating range limit: max. attainable range without performance reserve

2) Operating range: recommended range with performance reserve

3) Rating voltage 250VAC

4) 2=polarity reversal protection, 3=short circuit protection for all outputs

Order guide

	Designation	Part No.
with 6-pin standard plug		
Transmitter and receiver	LS 92/4.8-S	
Transmitter	LS 92/2.8 Se-S	500 11218
Receiver	LS 92/4 E-S	500 11217
with M12 connector		
Transmitter and receiver	LS 92/4.8-S.1	
Transmitter	LS 92/2.8 Se-S.1	500 20703
Receiver	LS 92/4 E-S.1	500 20704
with 6-pin standard plug without cable connector		
Transmitter and receiver	LS 92/4.8-S.1	
Transmitter	LS 92/2.8-Se-S.1	500 20360
Receiver	LS 92/4 E-S.1	500 20573