

Mounting CPSET- M21/-M22

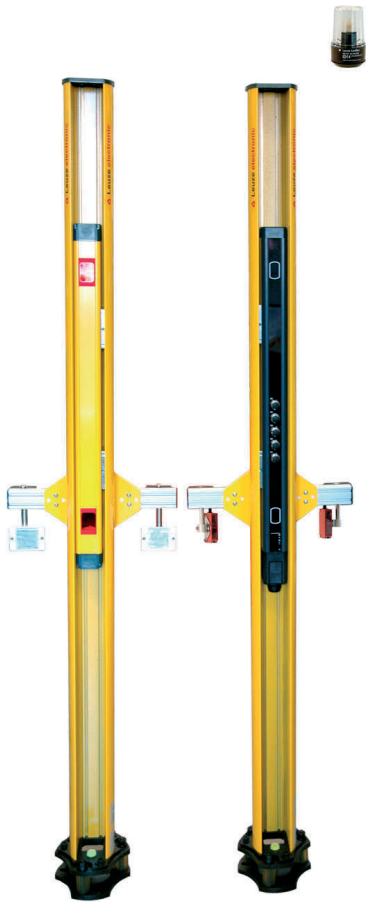

Required tools:

- 3, 4 and 6 mm Allen-type wrench
- 16 mm hexagonal wrench
- 17 mm hexagonal wrench
- Spirit level
- Electric drill with a 10 mm stone drill bit
- PC with installed SafetyLab software and PC cable with optical adapter

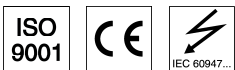

Leuze electronic GmbH + Co. KG
 Liebigstrasse 4
 82256 Fuerstenfeldbruck / Germany
 Phone +49 8141 5350-0
 Telefax +49 8141 5350-190
 info@leuze.de
 www.leuze.com

Procedure

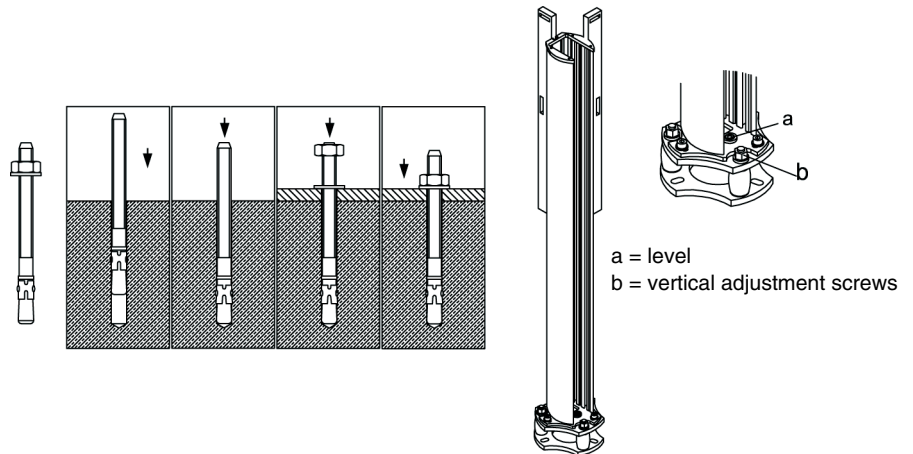

1. The devices come already mounted in the UDC device column. The installation height can be adjusted by loosening the Allen screws of the device brackets in the column.
2. Find the midpoints for mounting the columns and mark them on the floor.
3. Starting at the midpoints, mark the connecting lines on the floor approx. 90 mm long.
4. Place the drill template on the midpoints and align it with the connecting lines. Mark the hole positions.
5. Drill mounting holes 80 mm deep and insert foundation bolts.
6. Set up the columns, screw them firmly into place and adjust roughly using the level (a).
7. Using the adjustment screws (b), adjust the vertical position of the columns with the spirit level.
8. Mount MMS-A (fixing for muting sensors) and MMS-P (fixing with pre-mounted reflectors) on the slot on the rear of the device column.
9. Connect muting sensors in the front screen at connection sockets X2 and X3 of the receiver or transceiver.
10. Mount the muting lamp at a position that is easily visible for the operator and connect the cable to socket X5.
11. Connect start button to a socket of the sensor field or a terminal of the machine interface/R1.
12. Connect cable to machine interface/R1, integrate safety related switching output and connect power supply cable.
13. Switch on the devices and check that they are correctly aligned. Optimum alignment is achieved when the orange weak signal indicator on the receiver is no longer lit up.
14. Align muting sensors so that they are activated at the same time and the transport material is safely distinguished from people that enter the area.
15. Make further settings with the SafetyLab software via the optical PC cable in accordance with the application's requirements.