



# Bar Code Reader BCL 80 with Integrated Decoder Connector Unit MA 10

## Technical Description



All rights reserved, especially the rights of production, distribution and translation. Duplication or reproduction in any form (print, photocopies, microfilm or data) may only be carried out with the expressed written consent of Leuze electronic GmbH + Co.

We reserve the right to make changes for the technical improvement of the product

<b>1</b>	<b>General Information .....</b>	<b>3</b>
1.1	Explanation of Symbols .....	3
1.2	Definition of Terms .....	3
1.3	Declaration of Conformity .....	5
<b>2</b>	<b>Safety Notices .....</b>	<b>6</b>
2.1	Safety Standard .....	6
2.2	Intended Use.....	6
2.3	Working Safety.....	6
2.4	Organisational Measures.....	7
<b>3</b>	<b>Description .....</b>	<b>8</b>
3.1	The Bar Code Readers BCL 80 .....	8
3.2	Features of the BCL 80 .....	8
3.3	Construction.....	11
<b>4</b>	<b>Technical Data.....</b>	<b>13</b>
4.1	General Technical Data .....	13
4.2	Dimensioned drawings.....	15
4.3	Optical Data .....	16
4.3.1	Type overview.....	17
4.3.2	Sweep principle .....	17
4.3.3	Reading Fields.....	18
4.3.4	Scanning curves of the BCL 80 .....	19
<b>5</b>	<b>Accessories / Order Designation .....</b>	<b>21</b>
5.1	Connector and interface unit MA 10 .....	21
5.2	Mounting accessories .....	21
5.3	Cable accessories.....	23
<b>6</b>	<b>Installation .....</b>	<b>24</b>
6.1	Storage, Transportation .....	24
6.2	Mounting .....	25
6.2.1	Types of Mounting .....	25
6.3	Proper Configuration of the Devices .....	27
6.4	Connection .....	29
6.4.1	Connecting the BCL 80 for 'Stand Alone' Operation.....	30
6.4.2	Connecting the BCL 80 with the Connector Unit MA 10.....	32
6.4.3	Wire Lengths and Shielding.....	39
6.4.4	Disassembling, Packing, Disposing.....	39

<b>7</b>	<b>Commissioning</b> .....	<b>40</b>
7.1	Steps Before the First Commissioning .....	40
7.2	Function Test .....	42
7.3	Setting the Parameters .....	42
7.3.1	Service Operating Mode .....	44
7.3.2	Setting Parameters 'Offline' (Loading).....	46
7.3.3	Setting Parameters 'Online' .....	46
7.3.4	Setting the Bar Code Parameters Using 'autoConfig' .....	47
<b>8</b>	<b>Operation</b> .....	<b>48</b>
8.1	Display Elements .....	48
8.2	Important Functions During Operation .....	49
8.3	Error Handling .....	49
<b>9</b>	<b>Configuration</b> .....	<b>50</b>
9.1	Overview of Commands and Parameters .....	50
9.1.1	General 'Online' Commands .....	51
9.1.2	'Online' Commands for System Control .....	54
9.1.3	'Online' Commands for System Testing .....	55
9.1.4	'Online' Commands for Querying Statistical Data .....	56
9.1.5	'Online' Commands for Parameter Set Operations .....	57
9.1.6	'Online' Commands for BCL 80 with Oscillating Mirror .....	58
9.2	Setup Program .....	60
9.2.1	Overview of the Parameter Structure .....	60
9.2.2	Setting the Decoding Parameters .....	63
9.2.3	Setting the Output Format Parameters .....	65
9.2.4	Setting the Host Interface Parameters .....	69
9.2.5	Setting the Parameters of the Digital IN/OUT .....	71
9.2.6	Setting the General Parameters .....	73
9.2.7	Additional Functions: Setting the Reference Code Parameters .....	74
9.2.8	Additional Functions: Setting the 'autoControl' Parameters .....	75
<b>10</b>	<b>Maintenance</b> .....	<b>76</b>
10.1	General Maintenance Information.....	76
10.2	Repair, Service .....	76
<b>11</b>	<b>Appendix</b> .....	<b>77</b>
11.1	ASCII Table.....	77
11.2	Example Bar Code Label Types .....	80
11.2.1	Module 0.5 .....	80
11.2.2	Module 1.0 .....	82

# 1 General Information

## 1.1 Explanation of Symbols

The symbols used in this operating manual are explained below.

**Attention**

*Pay attention to passages marked with this symbol. Failure to heed this information can lead to injuries to personnel or damage to the equipment.*

**Attention Laser Radiation!**

*This symbol warns of possible danger through hazardous laser radiation.*

**Note!**

*This symbol indicates text which contains important information.*

## 1.2 Definition of Terms

**Activation**

Initiates a read process, e.g. by triggering the switched input.

**ASCII**

Standard character set (American Standard Code for Information Interchange) with 128 characters. Each character of the ASCII character set has been assigned a number from 0 to 127. This number is usually displayed in decimal format, but can also be displayed in hexadecimal or octal.

**Output format**

Determines the data format of the bar code information output from the decoder.

**autoConfig**

The function integrated into the bar code reader which automatically recognises the type and number of characters of the code to be read in.

**autoControl**

The function integrated into the bar code reader used to monitor the read quality.

**Bar code**

An arrangement of parallel bars and spaces which are arranged according to a standardised protocol such that they have a certain numeric or alphanumeric meaning.

**CRT**

The code reconstruction technology permits the reconstruction of the correct code from multiple fragments. This feature can be rather useful if, for some reason, the barcode reader is unable to read the entire label in one pass and needs to piece the code together from several "fragments."

**Deactivation**

End a read process, e.g. by using an online command.

### **Decoder/Decoding system**

The microprocessor control unit which translates the scanned bar code information into a simple signal that can be processed further.

### **Hex.**

Abbreviation for hexadecimal notation.

### **Host**

External computer or programmable logic controller (PLC) which is connected to the bar code reader via a serial interface and is used to further process the decoded bar code information.

### **Label**

Barcode label

### **Read quality**

The read quality can be monitored using the autoControl function. The relationship of the number of successful reads to the total number of reads is determined and monitored.

### **multiNet**

The network developed by Leuze for networking together several bar code readers.

### **No Read**

Read failure; a read process was initiated but a label could not be decoded.

### **Online command**

A command which is sent directly to the bar code reader from the host or a computer connected to the interface.

### **Parameter set**

The data set which is permanently stored in the bar code reader and contains all of the device settings.

### **PD**

Programming device

### **Postfix**

Trailer of the data transfer protocol (frame protocol) between the bar code reader and the host.

### **Prefix**

Header of the data transfer protocol (frame protocol) between the bar code reader and the host.

### **Protocol**

Interface protocol of the serial interface.

### **Frame protocol**

Transfer protocol for the data transfer between the bar code reader and the host.

### **Reference code**

Bar code, to be compared with scanned labels.

### **Scanner**

Bar code reader that optically scans the bar code with a laser beam.

### **Switched output**

Connection for output of status or event messages, e.g. after a failed read.

**Switched input**

Bipolar input for connecting a sensor or switch used for initiating a read process or for acquiring a reference code.

**Interface module**

Electronic component in the connector unit MA 10 which carries out the electrical adjustment of the various serial interface types (e.g. RS 232, RS 422, etc.).

**PLC**

Programmable logic controller. A PLC usually can be used as a host.

**Bar code**

An arrangement of parallel bars and spaces which are arranged according to a standardised protocol such that they have a certain numeric or alphanumeric meaning.

**Teach-In**

Programming a reference code using an example bar code.

### 1.3 Declaration of Conformity

The bar code reader BCL 80 and the connector unit MA 10 have been developed and produced in accordance with the applicable European standards and directives.

**Note!**

*The corresponding declaration of conformity can be requested from the manufacturer.*

The manufacturer of the product, Leuze electronic GmbH + Co. in D-73277 Owen/Teck, possesses a certified quality assurance system in accordance with ISO 9001.



## 2 Safety Notices

### 2.1 Safety Standard

The bar code reader BCL 80 and the connector unit MA 10 have been developed, produced and tested subject to the applicable safety standards. They correspond to the state of the art.

### 2.2 Intended Use

**Attention!**

*The protection of personnel and the device cannot be guaranteed if the device is operated in a manner not corresponding to its intended use.*

Bar code readers of the type BCL 80 are conceived as stationary, high-speed scanners with integrated decoders for all current bar codes used for automatic object recognition.

The connector and interface unit MA 10 simplifies the connection of the bar code reader of type BCL 80 / BCL 40 and adapts to various host interfaces. Connection to other bar code readers is not authorised.

In particular, unauthorised use includes:

- rooms with explosive atmospheres
- operation for medical purposes

**Fields of application**

The bar code reader BCL 80 with optional connector unit MA 10 is conceived particularly for the following fields of application:

- for package distribution and sorting installations
- for pallet transportation applications
- storage and conveying engineering, in particular for object identification on fast-moving conveyor belts
- pharmaceutical industry
- for all applications where great depth of focus and reading distances are required

### 2.3 Working Safety

**Attention Laser Radiation!**

*The BCL 80 is a laser device of laser class 2. Do not look directly into the laser beam. Observe the legal and local regulations applicable to the operation of laser units.*

- Never look at the laser beam directly (same as sunlight).
- Do not point the laser beam of the device to other persons.
- When mounting and adjusting the BCL, heed the reflection of the laser beam on reflective surfaces.
- Do not open the housing.  
Opening it does not interrupt the activation of the laser diode through read clocking.
- Heed the laser safety regulations according to DIN EN 60825-1 (most current version).

## **2.4 Organisational Measures**

### ***Documentation***

All entries in this operating manual must be heeded, in particular those in the sections "Safety Notices" and "Commissioning".

Carefully store this operating manual where it is accessible at all times.

### ***Safety regulations***

Observe the locally applicable legal regulations and the rules of the employers' liability insurance association.

### ***Qualified personnel***

Mounting, commissioning and maintenance of the device may only be carried out by qualified personnel.

Electrical work must be carried out by a certified electrician.

### ***Repair***

Repairs must only be carried out by the manufacturer or an authorised representative.

## 3 Description

### 3.1 The Bar Code Readers BCL 80

The bar code reader BCL 80 is a high-speed scanner with integrated decoder for all bar codes currently in use, e.g. 2/5 Interleaved, EAN, etc.

The many possible configurations of the device allow its adaptation to a multitude of reading tasks. Due to the large reading distance combined with the great depth of focus, the device is ideally suited for package and pallet transportation systems.

Together with the connector unit MA 10, it can easily be adapted for use with various interfaces, thus allowing additional processing by other systems. The MA 10 connector unit can also be used to network together several BCL 80 devices and to simplify electrical installation.

### 3.2 Features of the BCL 80

#### *Performance features*

- Maximum depth of focus
- Scanning rate: 600 Scans/s; application-specific adjustable
- Maximum reading distance of 2300 mm
- A switched input for triggering a read process using sensors
- Automatic monitoring of the read quality with the 'autoControl' function
- Automatic recognition of the bar code type using 'autoConfig'
- All device parameters can be set by software
- Heavy-duty housing of protection class IP 65 with corresponding cable
- RS 232 or RS 485 interface to host
- Extensive formatting possibilities for data output
- Reference code (comparison code)
- A version of the BCL 80 with an oscillating mirror add-on is available

#### *Added features with MA 10*

- Device status display with 4 LEDs
- RS 485 interface with electrical isolation for networking several devices
- Alternative interface RS 232, RS 422 or TTY using a selectable interface module with electrical isolation for directly connecting to the host
- Switched output for status messages (second output on request)
- Additional switched input for the definition of reference code 1
- Simple electrical connection via double terminal clamps, i.e. both the power supply and the interface circuits can easily be connected in series.
- Heavy-duty housing of protection class IP 65
- 2 parameter sets can be stored locally in the MA 10 (current parameter set, customer-specific parameter set)
- Built-in RS 232 service interface for fast commissioning or troubleshooting on site using a PC or programming device
- Switch for the autoConfig function

**Modular Concept**

**BCL 80 'stand alone'**

The bar code reader BCL 80 can be operated as an individual 'stand alone' (①) device. Electrical connection of the power supply, interface and switched input are centrally made via a 15 pin SubD socket. For connection, it is best to use the 15 conductor connection cable from Leuze. The requirements for protection class IP 65 are fulfilled when using this cable only (see Chapter 5)!

**BCL 80 with MA 10**

When using several BCL 80 units or under rough environment conditions, the installation of one connector unit MA 10 for each BCL 80 unit is recommended.

Electrical connection, commissioning, and service can be comfortably carried out in a short period of time.

The BCL 80 and MA 10 can be mounted directly together (②) or arranged separately next to each other. When mounted separately (③), the two units are connected by a cable. Protection class IP 65 is maintained when the sealed accessory cable is used (see Chapter 5).

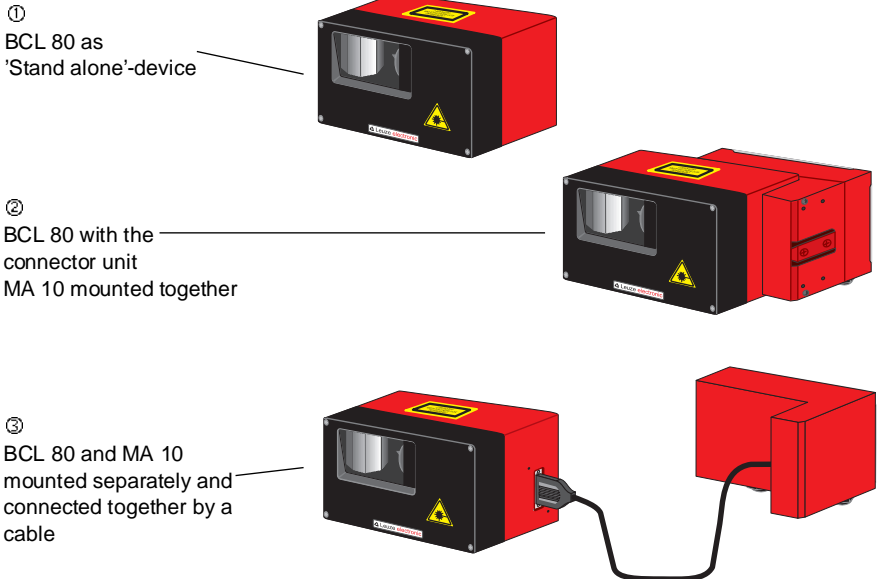

Figure 3.1: Possible combinations of the BCL 80 / MA 10

## Networking

Up to 31 BCL 80 bar code readers can be networked together using the connector unit MA 10 (with interface module RS 485). The devices are interconnected by connecting the individual RS 485 interfaces in parallel.

### multiNet plus

In the Leuze multiNet plus, the individual network devices sequentially transfer their data to the network master MA 30 when requested ('polling'). The master station can also be fitted with a BCL 80, making it a complete scanner station which also controls the network.

Each network device declared as a slave maintains a device address which is set in the respective MA 10 with a coding switch. If the reader unit is exchanged (BCL), the device address and all settings in the MA 10 are maintained.

The master then transmits the data of all network devices via its host interface to a primary PLC control system or a computer, i.e. it 'collects' the scanner data in the network and transmits them to **one** interface on the host computer. This reduces interface costs (CP's) and time programming the software.

Suitable network master devices are: DD 55, MDS 70 and MA 30.

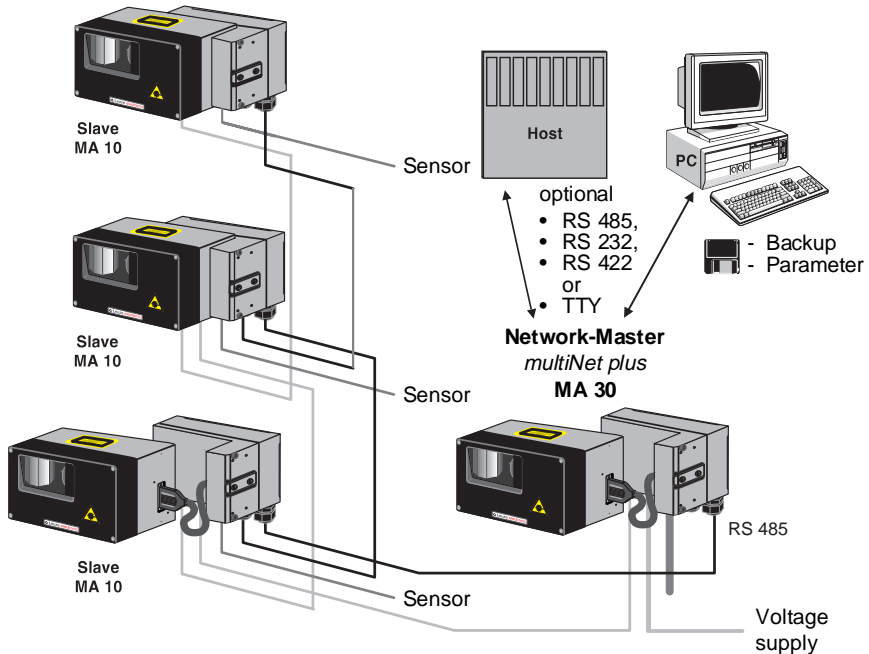

Figure 3.2: Networking possibilities using the multiNet plus

**Two-wire RS 485**

The Leuze MultiNet plus is optimised for fast transmission of scanner data to a primary host computer. The multiNet plus physically consists of a two-wire RS 485 interface through which the multiNet plus software protocol is controlled. This makes wiring the network easy and inexpensive since slaves are connected to each another in parallel.

**Interface modules**

Shielded, twisted pair conductors should be used for the multiNet. This allows a total network length of up to 1200 m. Connection of the network to the primary computer is made via the host interface of the MA 30 which can be equipped with 4 different physical interface modules. Modules for RS 232, RS 422, TTY and RS 485 are available.

**3.3 Construction**

**Device construction BCL 80**

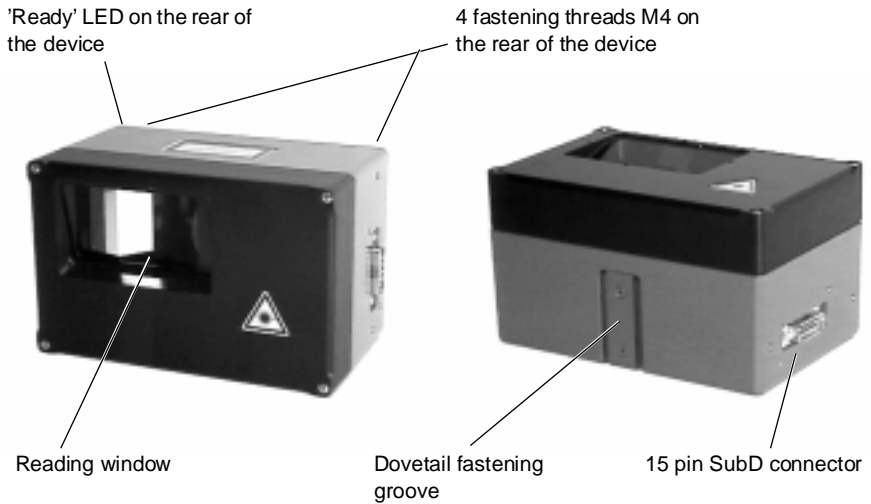

Figure 3.3: Bar code reader BCL 80

### Device construction MA 10

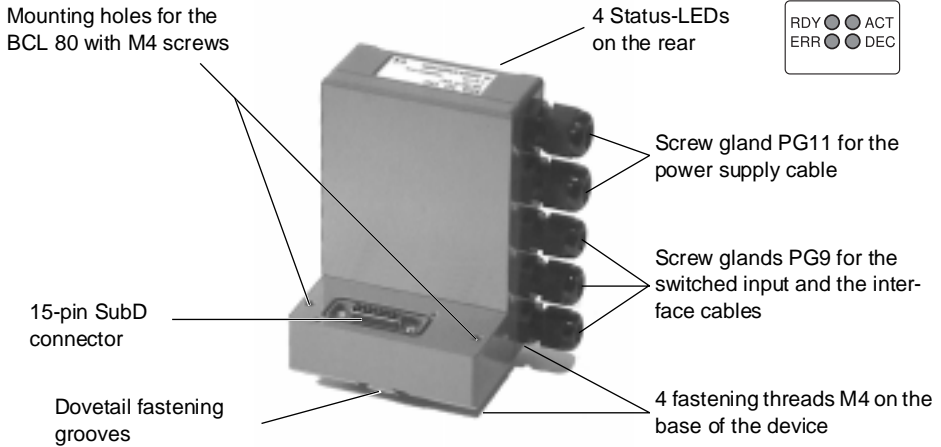

Fig. 3.4: connector unit MA 10

### Device variations MA 10

The MA 10 is available in four models:

- **MA 10 100** with host interface module RS 485
- **MA 10 110** with host interface module RS 232
- **MA 10 120** with host interface module TTY
- **MA 10 130** with host interface module RS 422

All modules are galvanically isolated, i.e. they are EMC interference protected and immune to differences in voltage potentials across long cable lengths.



#### **Note!**

Only the type MA 10 100 can be used as a multiNet slave unit.

## 4 Technical Data

### 4.1 General Technical Data

Manufacturer: Leuze electronic GmbH + Co., In der Braike 1, D-73277 Owen / Teck  
 Type: BCL 80, bar code reader with integrated decoder MA 10, connector / interface unit for BCL 80

#### **Technical Data BCL 80**

##### **General Specifications**

Housing Diecast aluminium  
 Dimensions 100 x 155 x 90 mm (H x W x D)  
 Weight approx. 1.63 kg  
 approx. 2.7 kg (version with oscillating mirror)  
 Protection class IP 65

##### **Scanner**

Resolution 0.2 ... 1 mm  
 Reading distance 300 ... 2300 mm  
 300 ... 1800 mm (version with oscillating mirror)  
 Scanning rate 600 Scans/s (adjustable)  
 Laser source laser diode, red 660 nm, 1 mW, protection class 2  
 Beam deflection by means of rotating polygon mirror wheel  
 Optical window glass with scratch-resistant Indium coating  
 Mirror oscillating frequency 0.2 ... 5.0 Hz (adjustable)

##### **Decoder**

Code types 2/5 Interleaved  
 Code 39  
 UPC (A, E)  
 EAN  
 Code 128 / EAN 128  
 Pharmacode  
 Add-On (EAN)  
 CODABAR  
 Code reconstruction all versions of the BCL 80 are available with optional code reconstruction technology

##### **Interfaces**

Type can be switched between RS 232 and RS 485, additional service interface (RS 232)  
 Baud rate 110 ... 57600 Baud selectable (host only)  
**Switching input** 12 ... 36 V DC / AC voltage, selectable galvanic isolation or supplied operating voltage, max. insulation voltage: 250 V (with galvanic isolation)

##### **Power supply**

Operating voltage 18 ... 36 V DC  
 Power consumption 6 VA max.  
 18 VA max. (version with oscillating mirror)

**Environmental conditions**

Operating temperature range	0 ... + 40°C
Storage temperature range	- 20 ... + 60°C
Air humidity	max. 90% rel. humidity, non-condensing
Vibration	accord. to IEC 68.2.6
Shock	accord. to IEC 68.2.27
EMC	accord. to IEC 801

**Technical Data MA 10**

**General Specifications**

Housing	Diecast aluminium
Dimensions	130 x 90 x 78 mm (H x W x D)
Weight	approx. 0.74 kg
Protection class	IP 65

**Interfaces**

Type (optional)	RS 232, with galvanic isolation RS 422, with galvanic isolation RS 485, with galvanic isolation TTY, with galvanic isolation
Service interface	RS 232 internal, 9 pin Sub D plug, male

**Inputs/outputs**

2 switched inputs	galvanically isolated, with supply voltage terminal for sensors 12 ... 36 V DC/AC, insulation voltage 500 V
2 switched outputs	can be operated galvanically isolated or not isolated switching voltage 5 ... 48 V DC, max. load 500 mA

**Power supply**

Operating voltage	18 ... 36 V DC
Power consumption	2 VA max.

**Environmental conditions**

Operating temperature range	0 ... +50°C
Storage temperature range	-20 ... +60°C
Air humidity	max. 90% rel. humidity, non-condensing
Vibration	accord. to IEC 68.2.6
Shock	accord. to IEC 68.2.27
EMC	accord. to IEC 801

4.2 Dimensioned drawings

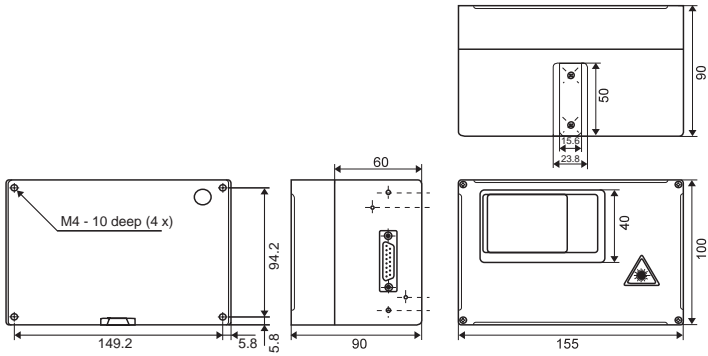

Figure 4.1: Dimensioned drawing BCL 80

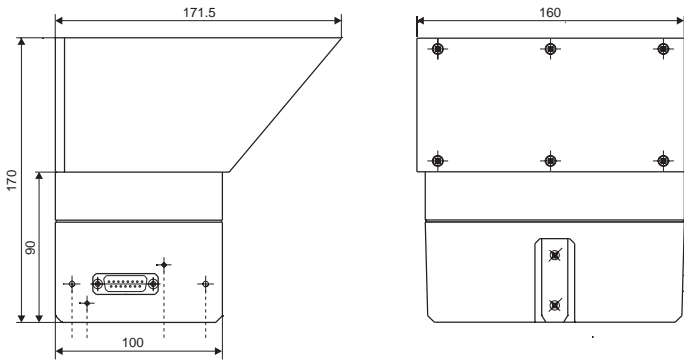

Figure 4.2: Dimensioned drawing of BCL 80 with oscillating mirror add-on

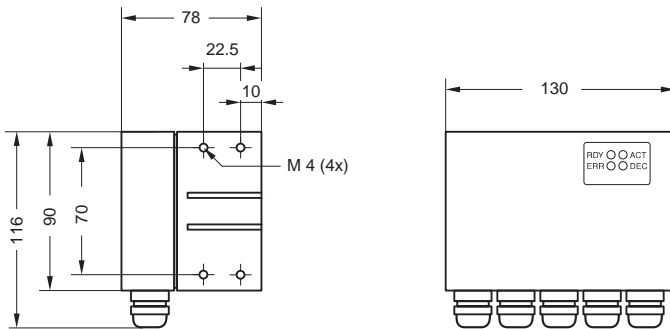

Figure 4.3: Dimensioned drawing MA 10

### 4.3 Optical Data

The range in which the bar code can be read by the BCL 80 (the so-called reading field) depends on the quality of the printed bar code and its dimensions.

Therefore, above all, the module of a bar code is decisive for the size of the reading field.

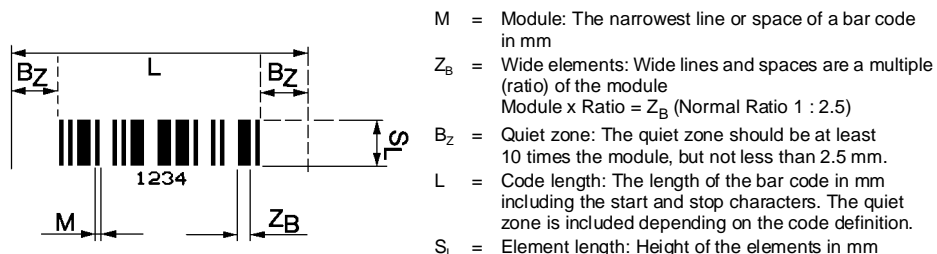

Figure 4.4: The most important characteristics of a bar code



**Note!**

*A rule of thumb: The smaller the module of the bar code is, the smaller the maximum reading distance and reading field width will be.*

*Therefore, when selecting a mounting location and/or the bar code label, take into account the different reading characteristics of the scanner with various bar code modules.*

The BCL 80 is available in various models for various reading tasks. A distinction is made between line scanners and line scanners with an oscillating mirror add-on. The latter may be used as de-facto raster scanners. For both varieties, there is also a version featuring code reconstruction technology (CRT). The device specifications are given in the following table and accompanying figure.

**4.3.1 Type overview**

Type	Maximum range (mm)	Module/ resolution (mm)	Sweep principle S*, OM** or R1***	Scanning rate (scan/s)	Part No.
BCL 80 S N1 100	500	0.2	S	600	500 31668
BCL 80 S N2 100	900	0.3	S	600	500 31669
BCL 80 S M 100	1600	0.5	S	600	500 26181
BCL 80 S L 100	2300	0.7	S	480	500 31607
BCL 80 O1 N1 100	500	0.2	OM	600	500 36447
BCL 80 O1 N2 100	800	0.3	OM	600	500 36449
BCL 80 O1 M 100	1400	0.5	OM	600	500 36450
BCL 80 O1 L 100	1800	0.7	OM	480	500 36451
BCL 80 CRT M 100	1600	0.5	S	600	500 29025
BCL 80 CRT O1 M 100	1400	0.5	OM	600	500 36452
BCL 80 R1 M 100	1600	0.5	R1	600	500 29221

S\*: Line Scanner Single Line (1 line)  
 OM\*\*: Line Scanner with oscillating mirror add-on  
 R1\*\*\*: Raster Scanner (8 lines)

**4.3.2 Sweep principle**

**Line scanner (single line)**

1 line scans the label.

**Areas of use:**

- when the bar code is printed in the conveying direction ('ladder arrangement')
- with bar codes having very short bar lengths
- when the scanning distance is large

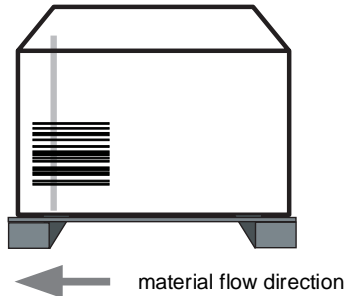

Figure 4.5: Sweep principle for the line scanner

**Line scanner with oscillating mirror add-on**

1 line that is continuously deflected by a mirror during scanning scans the label at varying heights.

**Areas of use:**

- when the label's position is not fixed, e.g., on palettes
- when the bar code is printed in the conveying direction ('picket fence arrangement')
- when reading stationary objects
- when the scanning distance is large
- when a large reading field has to be covered

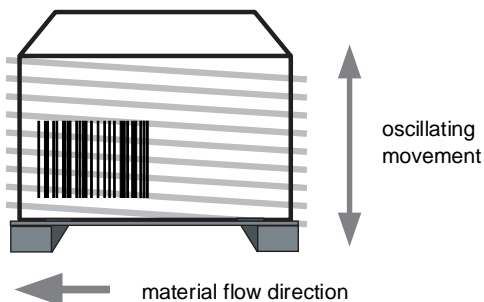

Figure 4.6: Sweep principle for the line scanner with oscillating mirror add-on

**4.3.3 Reading Fields**

The BCL 80 is available in two different versions (with / without oscillating mirror add-on) that also differ in range and resolution (see Chapter 4.3.1).

**Version S** (BCL 80 **S** N1 100 / BCL 80 **S** N2 100 / BCL 80 **S** M 100 / BCL 80 **S** L 100):

Standard version with / without CRT

Medium to very long range for barcodes with a medium module.

**Version O** (BCL 80 **O** N1 100 / BCL 80 **O** N2 100 / BCL 80 **O** M 100 / BCL 80 **O** L 100):

Version with oscillating mirror add-on and with / without CRT

Medium to very long range for barcodes with a medium module.

The following graphic displays the scanning curves of the various BCL models.



**Note!**

*Please note that the actual scanning curves can vary due to factors such as label material, print quality, reading angle, print contrast, etc.*

4.3.4 Scanning curves of the BCL 80

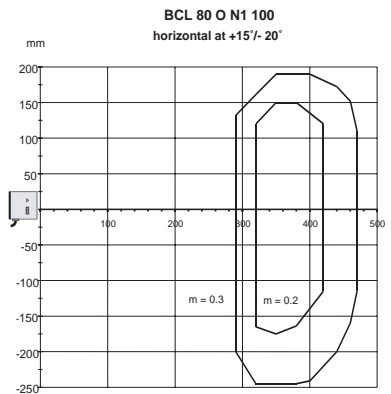
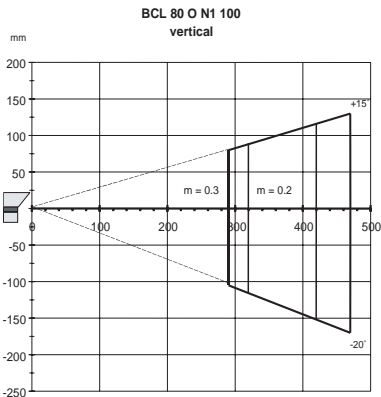
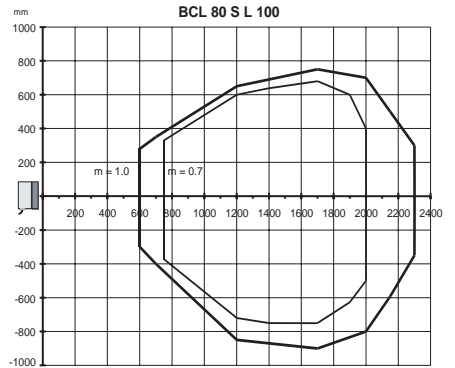
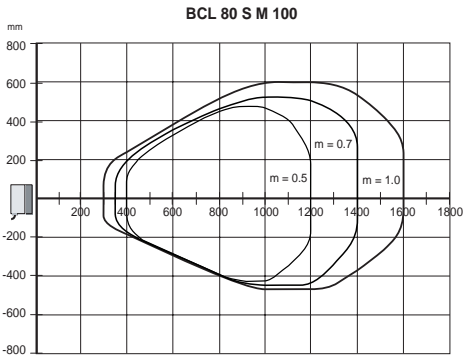
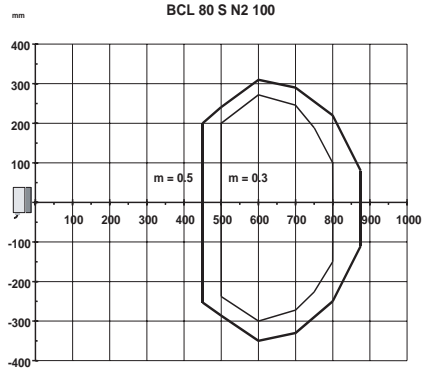
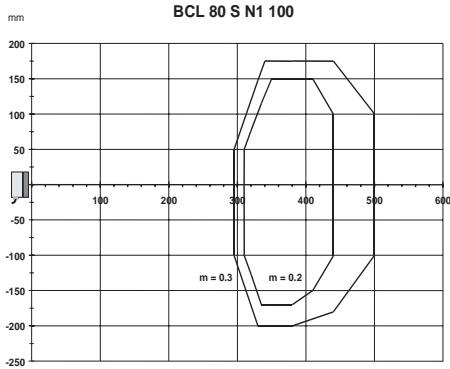

**BCL 80 O N2 100**  
vertical

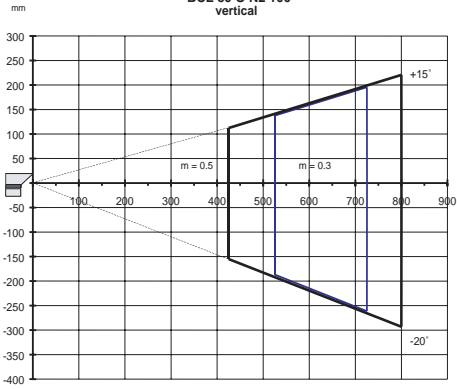

**BCL 80 O N2 100**  
horizontal at +15°/-20°

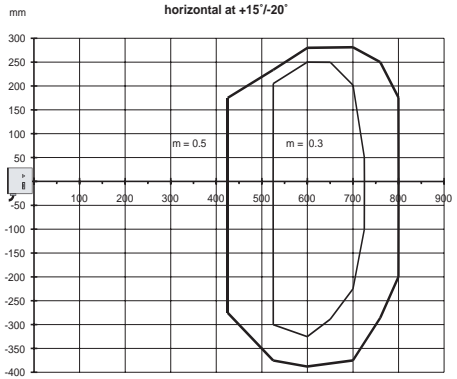

**BCL 80 O M 100**  
vertical

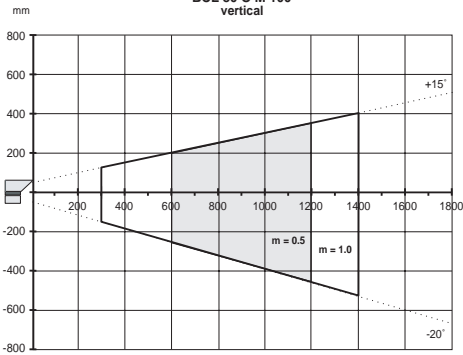

**BCL 80 O M 100**  
horizontal at +15°/-20°

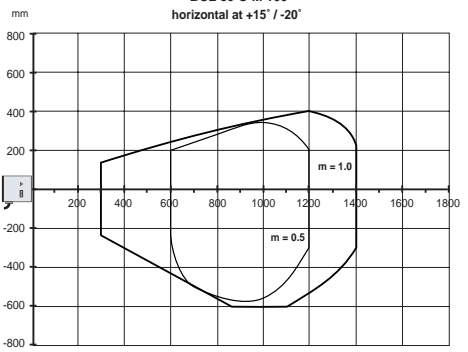

**BCL 80 OL 100**  
vertical

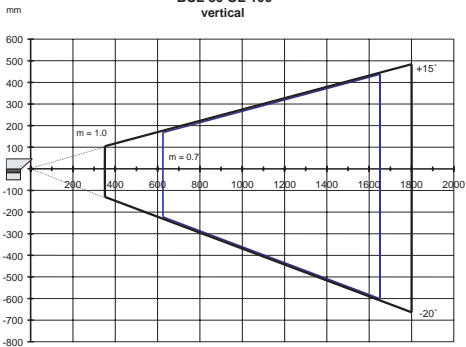

**BCL 80 OL 100**  
horizontal at +15°/-20°

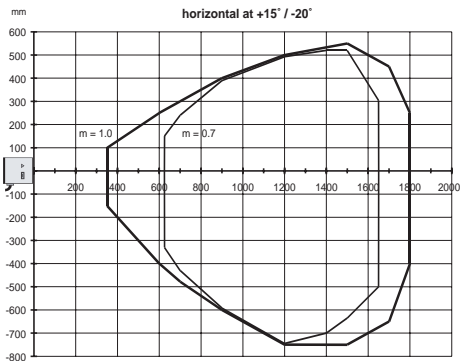

## 5 Accessories / Order Designation



**Addresses for ordering**

Products from Leuze electronic GmbH + Co. can be ordered from any of the sales and service offices listed on the back page of this operating manual.

### 5.1 Connector and interface unit MA 10

Type	Short Description	Part No.
MA 10 100	standard model, multiNet Slave with host interface RS 485	500 26110
MA 10 110	standard, with host interface RS 232	500 26109
MA 10 120	standard, active and passive operation with host interface TTY	500 27186
MA 10 130	standard, with host interface RS 422	500 27187



**Note!**

All MA 10 units are supplied with an additional RS 232 service interface (9 pin Sub D).

### 5.2 Mounting accessories

A wide range of mounting accessories are available for mounting the BCL 80 and MA 10.

**Mounting device BT 56**

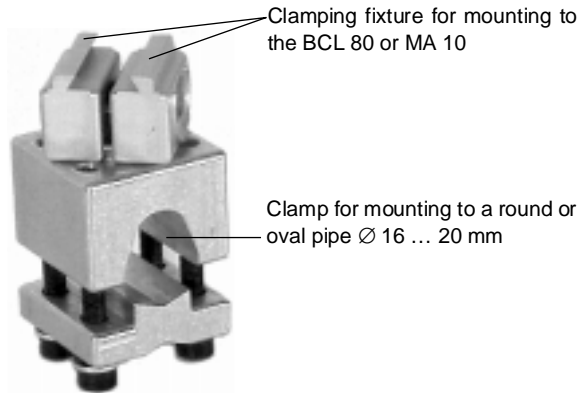

Figure 5.1: Mounting device BT 56



**Note!**

For weight reasons, the mounting kit BT 56 is not suitable for the version with oscillating mirror add-on.

**Mounting device BT 57**

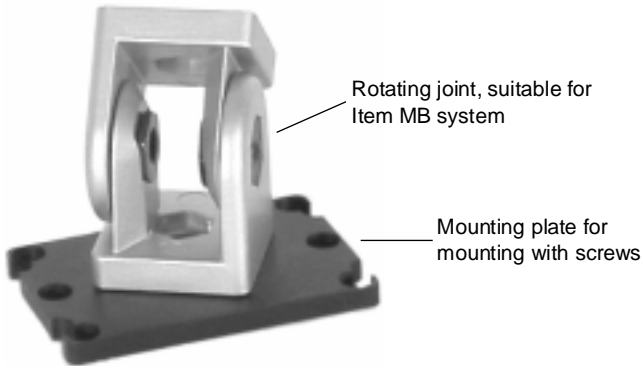

Figure 5.2: Mounting device BT 57

**Mounting device BT 58**

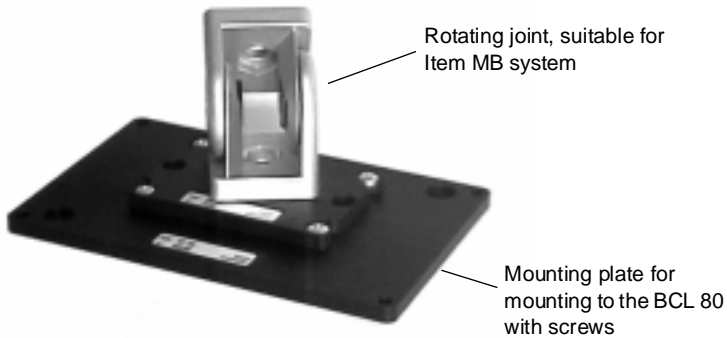

Figure 5.3: Mounting device BT 58

Type	Short Description	Part No.
BT 56	Mounting kit with dovetail for mounting on round rods Ø 16 ... 20 mm	500 27375
BT 57	Mounting kit suitable for ITEM MB system	500 27167
BT 58	Mounting kit suitable for ITEM MB system	500 27394

**5.3 Cable accessories**



**KB 040 xxxx**  
 15-conductor connection cable BCL 80 / MA 10,  
 Sub D plug and socket  
 xxxx = Length in mm

Figure 5.4: Connection cable between the BCL 80 and MA 10



**KB 040-xxxx-B**  
 15-conductor connection cable, Sub D socket  
 with open strand ends for connecting in switch-  
 ing cabinets or terminal boxes  
 xxxx = Length in mm

Figure 5.5: Connection cable BCL 80 'stand alone'

Type	Short Description	Part No.
KB 040-3000	15-conductor connection cable BCL 80 / MA 10, Sub D plug and socket, length: 3 m	500 26658
KB 040-6000	as above, length: 6 m	500 29381
KB 040-10000	as above, length: 10 m	500 29382
KB 040-3000-B	15-conductor connection cable BCL 80 'stand alone', open strand ends, Sub D socket, length: 3 m	500 29316
KB 040-6000-B	as above, length: 6 m	500 29317
KB 040-10000-B	as above, length: 10 m	500 29318



**Note!**

*The requirements for protection class IP 65 are fulfilled with this cable type only!*

**Software**

Type	Short Description	Part No.
BCL-Config	terminal software for on-line and off-line programming via PC or pro- gramming device with serial RS 232 interface (V.24)	500 31298

## 6 Installation

### 6.1 Storage, Transportation



**Attention!**

When transporting, package the device so that it is protected against collision and humidity. Optimal protection is achieved when using the original packaging. Heed the required environmental conditions specified in the technical data.

#### Unpacking

- Check the packaging for any damage. If damage is found, notify the post office or shipping agent as well as the supplier.
- Check the delivery contents using your order and the delivery papers:
  - delivered quantity
  - device type and model as indicated on the nameplate
  - Accessories
  - operating manual(s)

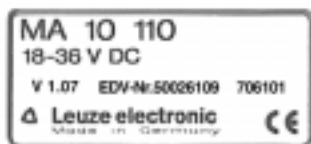

Figure 6.1: Device nameplates MA 10 and BCL 80

- Save the original packaging in case the device must be stored or shipped at a later time.

If you have any questions concerning your shipment, please contact your supplier or your local Leuze electronic sales office (see the last page of this operating manual).

- Observe the applicable local regulations when disposing of the packaging materials.

#### Cleaning

- Clean the glass window of the BCL 80 with a soft cloth before mounting. Remove any remaining packaging from the device such as cardboard fibres and Styrofoam balls, particularly in the area of the connector socket.



**Attention!**

Do not use aggressive cleaning agents such as thinner or acetone for cleaning the device.

## 6.2 Mounting

### 6.2.1 Types of Mounting

#### *Accessories*

A wide range of mounting accessories are available for mounting the BCL 80 and MA 10 (Chapter 5 "Accessories / Order Designation").

#### ***BCL 80 without oscillating mirror add-on***

##### ***Mounting the BCL 80***

There are two basic types of mounting arrangements for the BCL 80:

- using the dovetail groove and the corresponding mounting accessories
- using the fastening threads on the back- and underside of the devices (see Chapter 4.2 "Dimensioned drawings")

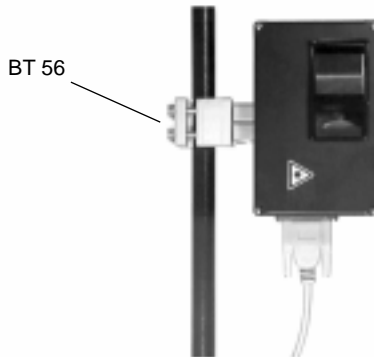

Figure 6.2: Mounting example BCL 80 'stand alone'

##### ***Mounting BCL 80 and MA 10***

You can fasten the scanner BCL 80 and connector unit MA 10 tightly together to form a single compact unit.

- Plug the two devices together at the 15 pin SubD connector. Be sure that there is no dirt in the area of the seal (this guarantees an IP 65 protection class). Insert the two M4 x 30 screws included with the connector unit MA 10 into the countersunk drill holes on the bottom side of the MA 10, screw them into the corresponding threads in the BCL 80 and tighten them down.

There are three basic mounting arrangements for the BCL 80 / MA 10 unit:

- using the dovetail groove of the BCL 80 or the MA 10 and the corresponding mounting accessories
- using the two upper fastening threads on the back side of the BCL 80
- using the four fastening threads on the underside of the MA 10 (see Chapter 4.2 "Dimensioned drawings")



**Note!**

The cable screw glands of the MA 10 can be set either on the right or the left side of the unit. Loosen the four Phillips screws on the back side of the MA 10, carefully lift off the cover, replace it into the desired position and tighten down the four screws again. Be careful not to damage the ribbon cable.



Figure 6.3: Mounting example for the combined BCL 80 / MA 10 unit

**Independent mounting BCL 80 / MA 10**

Independent mounting of the BCL 80 and MA 10 is necessary when

- the available mounting depth is not sufficient for both devices, e.g. is less than 85 mm, or
- access to the mounting location of the scanner is difficult, but easy installation, commissioning and service are required, or
- the operating status LEDs on the back side of the MA 10 must be easily seen.

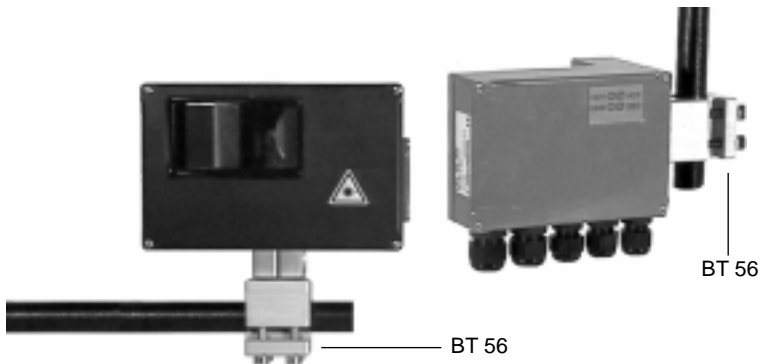

Figure 6.4: Mounting examples for the BCL 80 and MA 10 mounted independently

You can mount the individual devices in the following way as already described above:

- using the dovetail groove of the BCL 80 or the MA 10 and the corresponding mounting accessories
- using the fastening threads on the back- or underside of the devices
- the connector unit can additionally be mounted using two M5 screws into the threaded holes that are otherwise used for fastening the BCL 80. The threaded holes have M5 threads

***BCL 80 with oscillating mirror add-on***

For weight reasons, we do not recommend to mount the unit together with the MA 10. Always use a BT 58 when installing the BCL 80 with oscillating mirror.

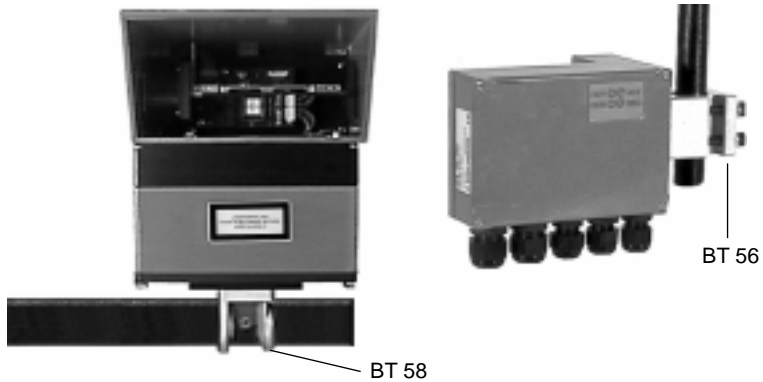

Figure 6.5: BCL 80 with oscillating mirror and MA 10, mounted separately

**6.3 Proper Configuration of the Devices**

***Selecting a mounting location***

In order to select the right mounting location, several factors must be considered:

- size, orientation, and position tolerance of the bar codes on the objects to be scanned
- the reading field of the BCL 80 in relation to the bar-code module width
- the resulting minimum and maximum reading distance from the respective reading field (see Chapter 4.3 "Optical Data")

The best reading results with the line scanner are obtained when

- the bar code is moved along the reading window at an angle of approx. 9 ... 15°
- the bars of the label are perpendicular to the scan line
- the reading distance lies in the middle area of the reading field
- high gloss labels or labels made from thermopaper are not used

Best reading results with the oscillating mirror version are obtained if

- the unit is tilted downwards by 10 ... 30° to avoid total reflections and to achieve the best depth of focus, or
- it is rotated by 5 ... 20° around its vertical axis.

**Large depth of focus**

Due to the large reading distance and the large depth of focus, the BCL 80 is especially suited for applications with varying goods or reading distances.

Examples are transport of pallets and packages, sorting and distribution applications.

**BCL 80 (oscillating mirror)**

Depth: 170

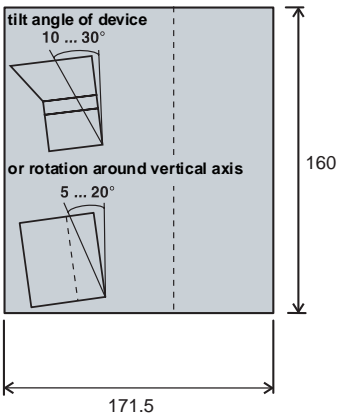

**BCL 80**

Depth: 100

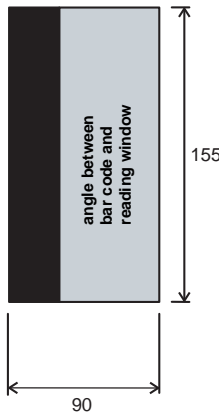

**BCL 80 and MA 10**

Depth: 100 + cabling space

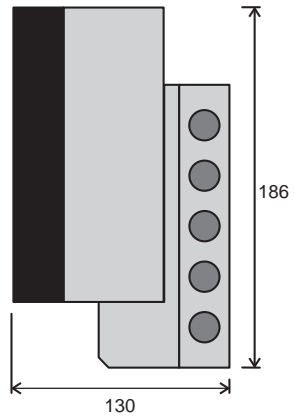

Figure 6.6: Minimum space requirements for installation



**Note!**

*The beam of the BCL 80 without oscillating mirror is emitted perpendicular to the housing's lid. Therefore, you should mount the unit at an angle of 9 ... 15° or move the labels past the housing at the same angle.*

When selecting a mounting location, pay attention to

- maintaining the required environmental conditions (temperature, humidity)
- possible soiling of the reading window due to liquids, abrasion by boxes, or packaging material residues
- reducing the chance of damage to the scanner by mechanical collision or jammed parts

**Application example: Packet conveyor belt**

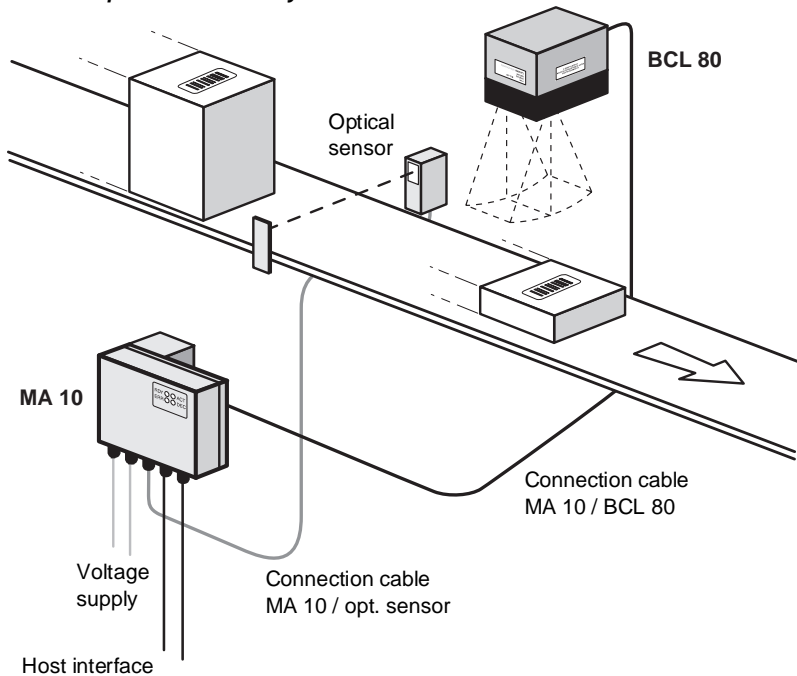

Figure 6.7: Application example 'Packet conveyor belt'

Due to the great depth of focus, the BCL 80 is ideally suited for packet and pallet transportation applications.

**6.4 Connection**



**Attention!**

*Connection of the device and maintenance work while under voltage must only be carried out by a qualified electrician.*

If faults cannot be corrected, the device should be removed from operation and protected against possible use.

Before connecting the device, be sure that the supply voltage agrees with the value printed on the nameplate.

The power supply unit used to power the BCL 80 and MA 10 must have protected electrical separation by way of a safety transformer with double insulation according to DIN VDE 0551 (equivalent IEC 742).

Be sure that the earthing conductor is connected correctly. Error-free operation is only guaranteed when the device is properly earthed.

### 6.4.1 Connecting the BCL 80 for 'Stand Alone' Operation

If you would like to connect the BCL 80 for 'stand alone' operation, you must make a corresponding connector cable with a 15 pin SubD plug (female) for the following connections:

- power supply of 18 ... 36 V DC, 5 W max. power
- host RS 232 interface, or RS 485 when operating as a 'multiNet slave'
- a sensor connection for triggering a read process

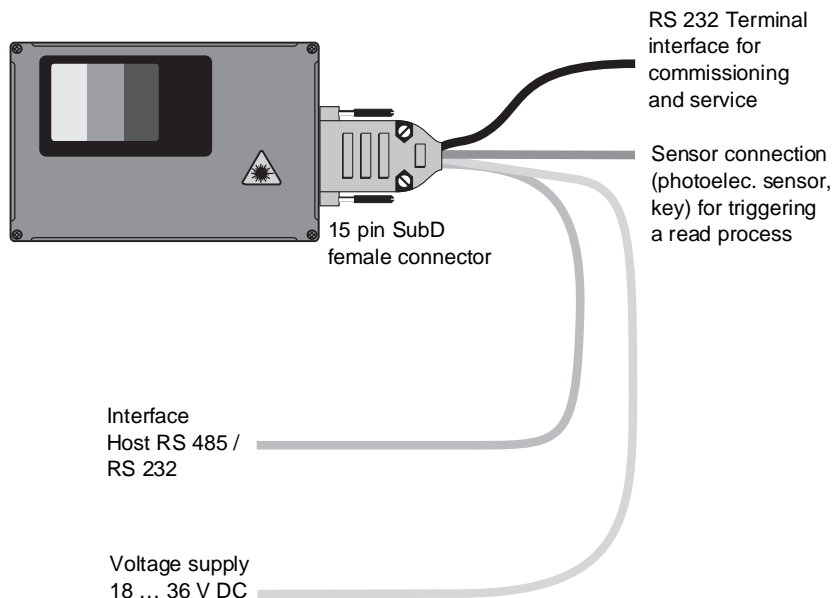

Figure 6.8: Connecting the BCL 80 'stand alone'



#### **Attention!**

*When using a normal 15 pin SubD plug, the device only has a protection class of IP 54 instead of IP 65! Therefore, use the original Leuze cable from the accessories list. These cables are fitted with a seal so that protection class IP 65 is maintained.*

#### **Switching inputs**

A read process can be triggered by applying a voltage of 12 ... 36 V DC to the switched input connections 'Sensor 1A' and 'Sensor 1B'. The switched input maintains an electrical separation of up to max. 250 V.



15 pin SubD type connector (male)

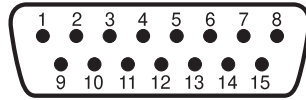

- 1 GND
- 2 Sensor 1A
- 3 CTS (Host)
- 4 RTS (Host)
- 5 TXD Service
- 6 MODE\_F
- 7 reserved
- 8 V\_IN
- 9 Sensor 1B
- 10 NC
- 11 RXD (Host)
- 12 TXD (Host)
- 13 RXD Service
- 14 MODE\_S
- 15 GND\_IN

**Operating mode**

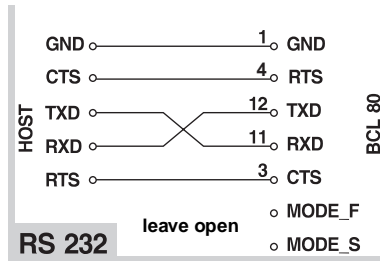

Insert a resistor R = 220 Ω / 0.25 W here, if the device is the **last** subscriber on the RS 485 data line. Do not use a resistor, if the RS 485 line continues.

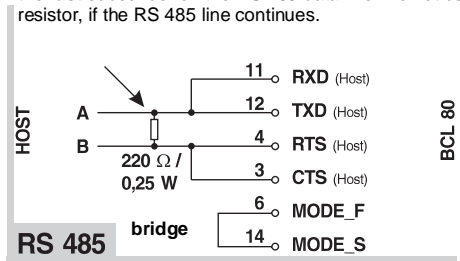

Figure 6.9: Connection diagram for the SubD connector plug

**Wiring description**

Pin 1	GND	0 V signal reference potential (RS 232 / RS 485)
Pin 2	Sensor 1A	switched input 1A, 12 ... 36 V DC, see fig. 6.18 and 6.19 for wiring
Pin 3	CTS (Host)	CTS signal, host interface RS 232 / RS 485 B
Pin 4	RTS (Host)	RTS signal, host interface RS 232 / RS 485 B
Pin 5	TXD service	used when MA 10 is connected / without MA 10: service interface, standard protocol
Pin 6	MODE_F	RS 232: open; RS 485: connect with MODE_S
Pin 7	Reserved,	must not be used
Pin 8	V_IN	supply voltage + 18 ... 36 V DC
Pin 9	Sensor 1B	switched input 1B, 12 ... 36 V DC, see fig. 6.18 and 6.19 for wiring
Pin 10	NC	not used
Pin 11	RXD (Host)	RXD signal, host interface RS 232 / RS 485 A
Pin 12	TXD (Host)	TXD signal, host interface RS 232 / RS 485 A
Pin 13	RXD service	used when MA 10 is connected / without MA 10: service interface, standard protocol
Pin 14	MODE_S	RS 232: open; RS 485: connect with MODE_F
Pin 15	GND_IN	Supply voltage 0 V DC

### 6.4.2 Connecting the BCL 80 with the Connector Unit MA 10

Connection of the BCL 80 is considerably easier when using the MA 10.

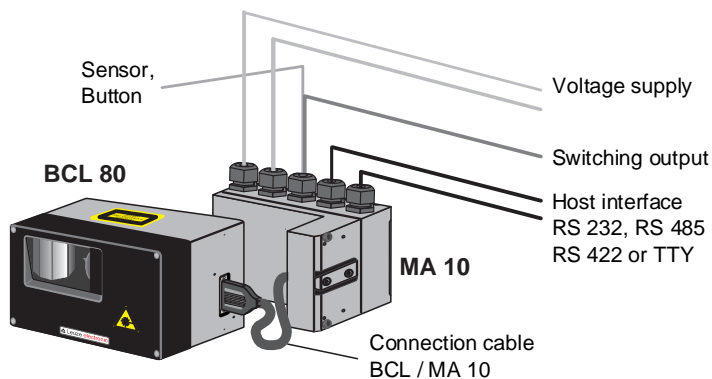

Figure 6.10: Connecting the BCL 80 with the connector unit MA 10

#### **Open the MA 10 housing**

- Loosen the four Phillips screws on the back side of the MA 10 and carefully lift off the part with the electronics on it.

The two halves of the housing are now connected to each other only by the ribbon cable. You can now disconnect the ribbon cable from the electronic circuit board for better access, as shown in Figure 6.11.

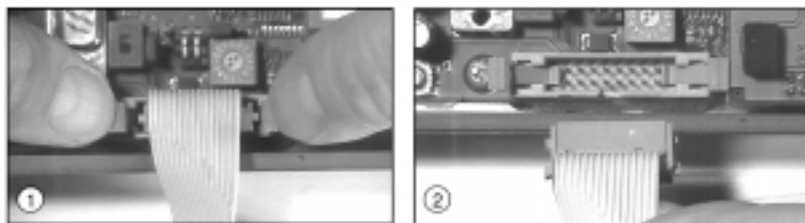

Figure 6.11: Disconnecting the ribbon cable inside the MA 10

- To disconnect the ribbon cable, carefully press down the two latches of the ribbon cable plug at the same time, as shown in ① of Figure 6.11.

The cable is now free (② in Figure 6.11) and the half with the electronics and the connection terminal can be removed for unhindered connection.

- To reconnect the ribbon cable, insert the ribbon cable plug back into its socket, observing the correct orientation, until it securely latches.



**Note!**

All electrical connections can be carried out on the terminal strip quickly and without screwing down or soldering. Wires with ferruled ends can be inserted directly into the terminal without depressing the clamping lever.

The clamp is opened by depressing the orange coloured clamping lever.

The wire can then be inserted into the terminal.

By releasing the clamping lever, the wire is fixed into the terminal.

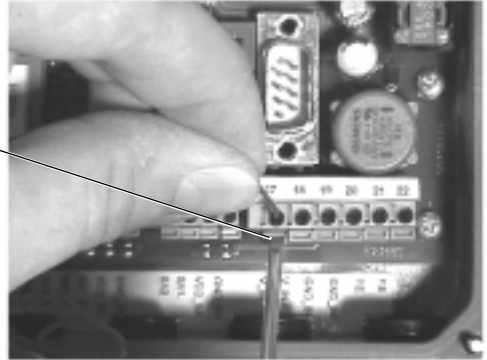

Figure 6.12: Wiring to the terminal strip without screwing down or soldering



**Attention!**

The pin assignment of the connection terminals depends on the inserted interface module. Leuze offers four modules which can be used with the serial interfaces RS 485, RS 232, TTY or RS 422. The terminal designations are printed on the module.

Attached label with the pin assignments of the interface

Terminal strip

Attached label with the terminal names

Cable screw glands PG9 and PG11

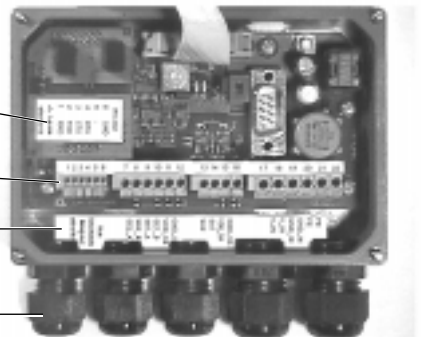

Figure 6.13: Position of the connections for the MA 10

**Type overview**

The following table lists the MA 10 device types and which interface is installed.

MA 10 100	RS 485 interface
MA 10 110	RS 232 interface
MA 10 120	TTY interface
MA 10 130	RS 422 interface

- Make the connections to the terminal strip as described below.

**Wiring description**

Terminals 1 through 6 are used depending on the type of interface:

RS 232		RS 422	
Terminal	Signal	Terminal	Signal
1	RXD	1	TX+
2	TXD	2	TX-
3	CTS	3	RX+
4	RTS	4	RX-
5	not used	5	not used
6	GND	6	GND

RS 485		TTY	
Terminal	Signal	Terminal	Signal
1	485A	1	TX+
2	485A	2	TX-
3	485B	3	RX+
4	485B	4	RX-
5	GND	5	not used
6	GND	6	GND

**RS 485 Interface**

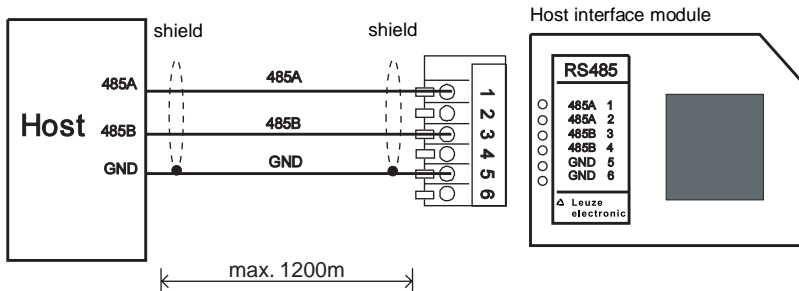

Figure 6.14: Connecting the MA 10 to a RS 485 Host

RS 232 Interface

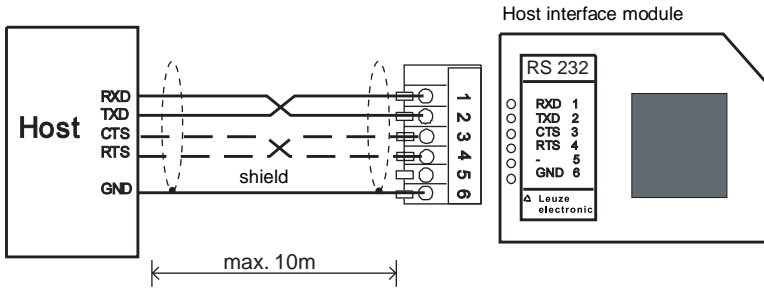

Figure 6.15: Connecting the MA 10 to a RS 232 Host



**Notice for connecting the RS 232 interface!**

The wiring for RTS and CTS must only be connected, if RTS/CTS hardware-handshake is used.

TTY interface

MA 10 active / Host passive

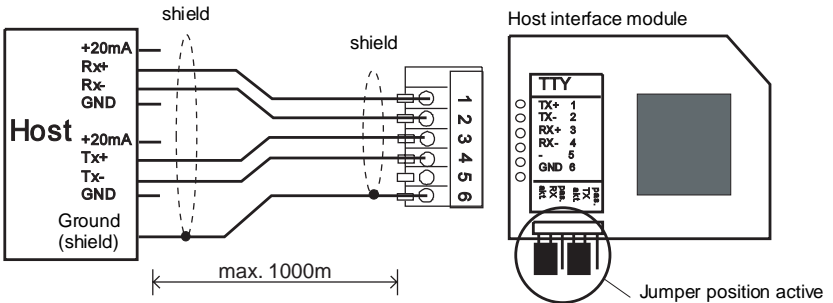

Figure 6.16: Connecting the MA 10 as active subscriber to a TTY Host

MA 10 passive / Host active

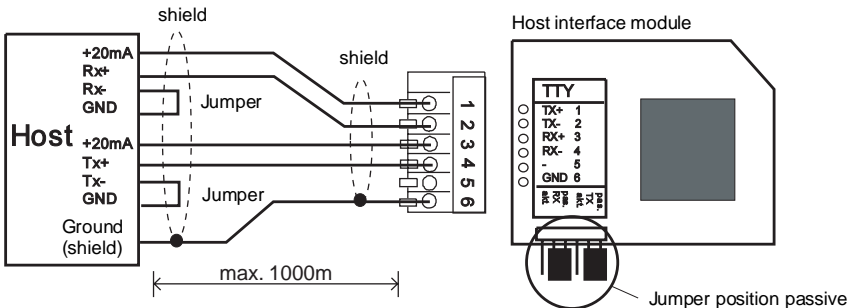

Figure 6.17: Connecting the MA 10 as passive subscriber to a TTY Host



**Remarks for connecting the TTY interface!**

- The active subscriber is the one which supplies the current (20 mA).
- Switching between active/passive on the host interface card is carried out using two jumper pairs, independent for transmit (Tx) and for receive (Rx).
- The jumpers for active/passive switching must always be changed in pairs (upper and lower jumpers in the same position). This switches the MA 10 host interface module power source and GND internally.
- Mixed operation is possible (transmit active/receive passive or the opposite).
- When switching from active to passive operation or the reverse, the wiring of the connection cable (pin order) changes.

**RS 422 Interface**

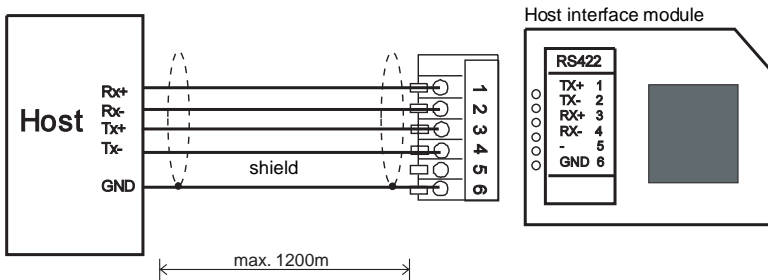

Figure 6.18: Connecting the MA 10 to a RS 422 Host

The additional pins are uniformly assigned for all MA 10 models and are described below.

**Switching inputs**

The MA 10 has two galvanically isolated switching inputs SE1 and SE2.

- Input voltage: 12 ... 36 V DC / AC.
- Insulation voltage: 500 V

Each switching input has an optical coupler and is wired with a protection resistor.

The switching voltage and GND can be externally applied or taken from the operating voltage VDD\_SE and GND\_SE.

Terminal	Signal	Function
7	SE2_A	switching input 2, connection A
8	SE2_B	switching input 2, connection B
9	SE1_A	switching input 1, connection A
10	SE1_B	switching input 1, connection B
11	VDD_SE	supply voltage, switching input, equal to V_IN device
12	GND_SE	supply voltage, switching input, equal to GND_IN device

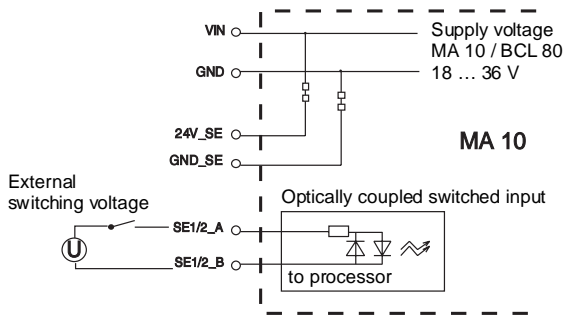

Figure 6.19: Connection of the switching input with an external switching voltage

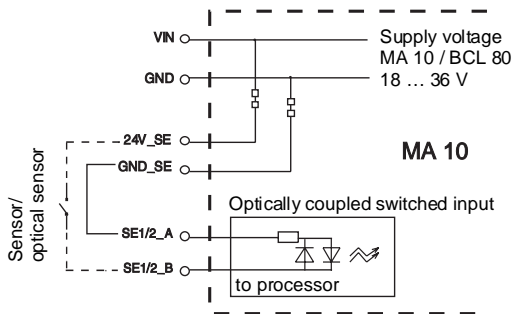

Figure 6.20: Connection of the switching input without an external switching voltage

**Switching outputs**

The MA 10 comes standard with two switching outputs (SA1 and SA2) that can be programmed for various switching functions using the BCL software.

- Output voltage: 5 ... 48 V DC
- Insulation voltage: 250 V (only in combination with connection type **b**)
- Output current:  $I_{max} = 500 \text{ mA}$  (at  $V_{DD\_SA} = 5 \dots 32 \text{ V}$ )  
 $I_{max} = 300 \text{ mA}$  (at  $V_{DD\_SA} = 32 \dots 48 \text{ V}$ )

The switching voltage can be connected in two different ways:

- a** The operating voltage  $V_{IN}$  is used as the switching voltage  $V_{DD\_SA}$  (factory setting):  
 $V_{DD\_SA} = V_{IN}$   
 $GND\_SA = GND_{IN}$
- b** An external voltage is connected as the switching voltage (galv. decoupled)  
 $V_{DD\_SA} \neq V_{IN}$   
 $GND\_SA \neq GND_{IN}$

Terminal	Signal	Function
13	SA2	Switching output 2
14	SA1	switching output 1
15	VDD_SA	external voltage supply for switched output 5 ... 48 V DC
16	GND_SA	external voltage supply for switched output 0 V DC

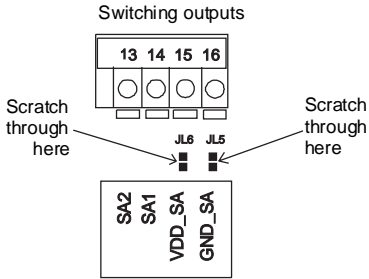

**Galvanic decoupling of the switched output**

Galvanic decoupling is achieved by carefully scratching through the two solder jumpers JL5 and JL6 so that there is no longer an electrical connection. The switched output is then galvanically decoupled from the operating voltage. The solder jumpers are located on the circuit board of the MA 10 directly across from the connection terminals VDD\_SA and GND\_SA.

Figure 6.21: Position of the solder jumpers JL5 and JL6

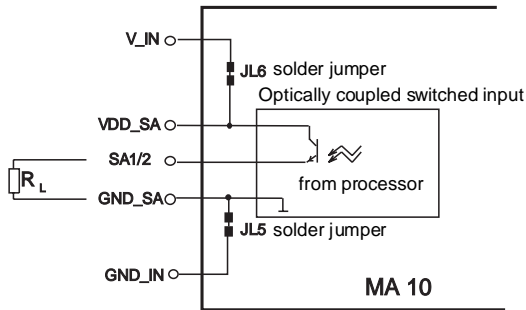

Figure 6.22: Operating voltage used as the switching voltage

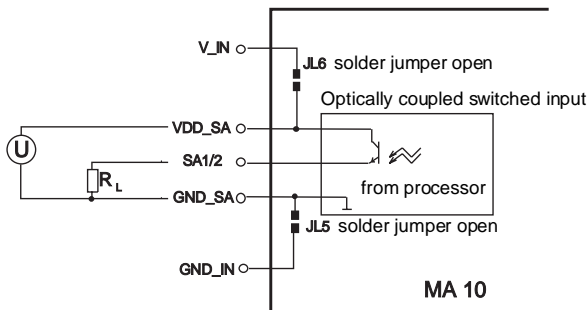

Figure 6.23: Switching voltage connected externally (galvanically decoupled)

**Controlling the function of the switching outputs**

The function of the switching outputs can be controlled by removing the cover to the MA 10. Sitting directly next to the connection terminals for the switching outputs are red SMD-LEDs that illuminate when the respective switching output is in the HI state (log.1). Please note that the event which sets the switching outputs must be set and activated in the software setup of the BCL 80.

**Supply voltage**

Terminal	Signal	Function
17	V_IN	Operating voltage +18 ... 36 V DC
18	V_IN	Operating voltage +18 ... 36 V DC
19	GND_IN	Operating voltage 0 V DC
20	GND_IN	Operating voltage 0 V DC
21	PE	Protective earth, grounding
22	PE	Protective earth, grounding

**6.4.3 Wire Lengths and Shielding**

The following maximum lengths for wires and the type of shielding to be used must be observed:

Connection	Interface	Max. wire length	Shielding
BCL 80 - MA 10	RS 232 / RS 485	10 m	absolutely required, braided shielding
BCL 80 - Host	RS 232 / RS 485	10 m	absolutely required, braided shielding
MA 10 - Host	RS 485	1200 m	absolutely required, flexible leads as twisted pairs
MA 10 - Host	RS 422	1200 m	absolutely required, flexible leads as twisted pairs
MA 10 - Host	RS 232	10 m	absolutely required, flexible leads as twisted pairs
MA 10 - Host	TTY	1000 m	not required loop resistance < 100 Ω
Switched inputs		10 m	not necessary
Switched outputs		10 m	not necessary

**6.4.4 Disassembling, Packing, Disposing**

**Repacking**

For later reuse, the device is to be packed so that it is protected against shocks and dampness. Optimal protection is achieved when using the original packaging.



**Note!**

*Electrical scrap is a special waste product!  
Observe the locally applicable regulations regarding disposal of the product.*

## 7 Commissioning

### 7.1 Steps Before the First Commissioning

- Before commissioning, familiarise yourself with the operation and configuration of the device(s)!
- Before switching on, recheck all connections and ensure that they have been properly made.

DIP switch 1 'ParaDefault':

- ON At Reset ('cold start')  
the factory default  
parameter set is loaded
- OFF At Reset ('cold start')  
customer specific  
parameter set is loaded

DIP switch 2 'autoConfig' and

- parallel connected jumper:  
ON 'autoConfig' function  
activated
- OFF 'autoConfig' function  
deactivated

Reset button:

- Press < 4 s:  
'warm start'
- Press > 4 s:  
'cold start'

Coding switch 0 ... F for setting the  
device address:

The switch positions 0 ... F  
correspond to the device address  
0 ... 15 or 16 ... 31.

Jumper for setting the device

address range:

- Right jumper Adr. 0 ... 15
- Left jumper Adr. 16 ... 31

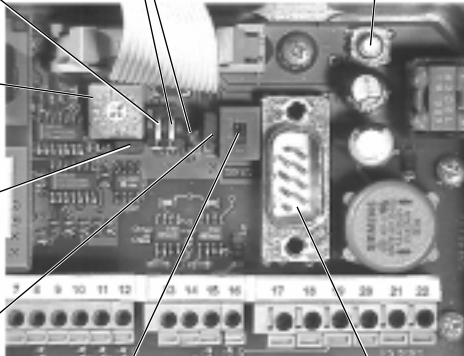

Data logging jumper for the inter-  
face terminal

- Jumper above: Data from  
Host
- Jumper below\*: Data from  
BCL

Operating modes switch:

- Switch setting 1: SERVICE\*
- Switch setting 2: OPERATION

Interface terminal

RS 232 for commiss.  
and service

\*In service operation, the jumper must be in the "lower" position.  
Communication is otherwise not possible.

Figure 7.1: Control elements of the MA 10

#### **Setting the device address**

The device address is set in the MA 10 using a rotary code switch.

- Set the device address on the code switch to:
  - 0, if the combined BCL 80 / MA 10 unit will not be operated in a network,
  - 1 ... 31, if several BCL 80 / MA 10 units will be operated in a network. Each multiNet plus network device must have a different device address assigned to it. If the RS 485 module is plugged in and connected to the multiNet master, the BCL 80 / MA 10 automatically becomes a multiNet plus slave device.

**Reset**

Both devices can be reset using the reset button in the MA 10:

**'Warm start'**

If the reset button in the MA 10 is pressed for a short time (0.2 to 4 sec.), a so-called 'warm start' will be carried out. This will reinitialise both devices and load the current parameter set into memory from the EEPROM.

**'Cold start'**

If the reset button in the MA 10 is pressed until all four LEDs on the back of the device illuminate (longer than 4 seconds), a so-called 'cold start' will be carried out. This will reinitialise both devices and, depending on the DIP switch setting 'ParaDefault', will either load the customer-specific parameter set or the factory default parameter set into memory.

DIP switch setting 1 'ParaDefault':

- OFF - the customer-specific parameter set is loaded.
- ON - the factory default parameter set is loaded.



**Note!**

*The customer-specific parameter set is a backup copy of the current parameter set. It must be explicitly loaded using the command 'PC01' after saving the BCL setup and is only available in the MA 10 (not the BCL 80).*

*The customer-specific parameter set can then be loaded by executing a 'cold-start'.*

*See Chapter 9.1.6: 'Online commands for parameter set operations'*

- Set DIP switch 1 corresponding to the parameter set that should be loaded after a 'cold start' has been initiated.

After resetting the device, all four LEDs on the back side of the MA 10 illuminate for approx. 0.5 second. During software initialisation, the green 'RDY' (ready) LED blinks.

If the green 'RDY' LED continuously illuminates, the initialisation is complete and the device is ready for operation.



**Note!**

*If the BCL 80 is to be operated as a 'stand alone' device, a reset is only possible via software. There is a small green LED inside the BCL 80 at the lower edge of the reading window that displays the operation readiness. The LED can also be used to monitor the operating status of the BCL 80 in 'stand alone' operation. During a reset, the LED remains dark and continuously illuminates when the device is ready for operation.*

## 7.2 Function Test

### ***'Power On' test***

After connecting the operating voltage, the devices carry out an automatic 'Power On' function test. All four LEDs on the back of the MA 10 illuminate for approx. 0.5 second. During software initialisation, the green 'RDY' (ready) LED blinks.

Once the green 'RDY' LED continuously illuminates, the device is ready for operation.

### ***Interface***

Proper functioning of the interface can be checked easiest in the service mode via the service interface with a suitable terminal program (BCL Config) and a PC (notebook, see Chapter 5 "Accessories / Order Designation").

### ***'Online' commands***

Using the 'Online' commands, the important device functions can be checked, e.g. proper functioning of the laser (see Chapter 9.2.2 and following).

### ***Problems***

If problems are encountered during commissioning of the device, check first under Chapter 8.3 "Error Handling".

Should the problem persist after checking all electrical connections and settings on the device and host, contact a Leuze service office (see last page of this operating manual).

## 7.3 Setting the Parameters

Three different parameter sets are maintained by the MA 10 when using the BCL 80 / MA 10 combined unit:

- the factory default parameter set
- the customer-specific parameter set
- the current parameter set

Before a parameter set is loaded into the BCL 80 processor memory, the validity of the parameter set is checked using checksums.

### ***Factory default parameter set***

This parameter set contains the default settings made ex works for all BCL 80 parameters. It is permanently stored in the ROM of the BCL 80. The parameter set with the default settings is loaded into the memory of the BCL 80

- the first time the device is commissioned after delivery
- after a 'cold start' reset ('ParaDefault' switch ON)
- if the check sums of the current and the customer-specific parameter set are invalid

**Customer-specific parameter set**

In this parameter set, customer-specific settings for all device parameters can be stored. There are two ways to store the parameter set in the EEPROM of the MA 10:

- by copying a valid parameter set, i.e. an already stored and tested 'current parameter set' from the EEPROM of the MA 10.
- by copying (parameter 'Download') a valid parameter set from the host computer (e.g. a PC or PLC).

The customer-specific parameter set is copied into the current parameter set

- after a 'cold start' reset ('ParaDefault' switch OFF)
- if the checksum of the current parameter set is invalid

**Current parameter set**

In this parameter set, the current settings for all device parameters are stored. If the BCL 80 is in 'stand alone' operation, the parameter set is stored in the EEPROM of the BCL 80. If an MA 10 is also used, the parameter set is stored in EEPROM of the MA 10 and a copy thereof in the EEPROM of the BCL 80. The current parameter set can be stored in three ways:

- by changing and storing the current parameter set using the integrated SETUP program of the BCL 80
- by copying (parameter 'Download') a valid parameter set from the host computer (e.g. a PC or PLC).
- by means of an OFF line setup with the PC setup program BCL Config

The current parameter set is loaded into the memory of the BCL 80

- each time the supply voltage is connected
- after a 'warm start' reset, as well as a software reset

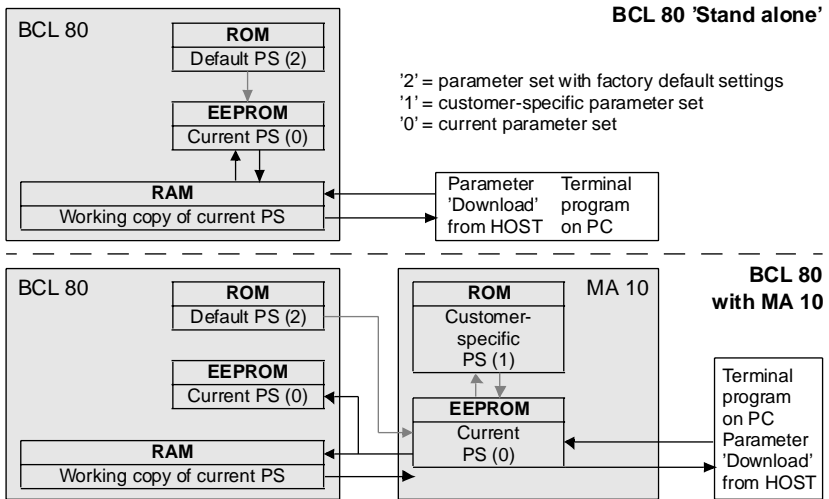

Figure 7.2: Block diagram storage concept for parameter sets

**Note!**

By storing all current and customer-specific values in the connector unit MA 10, a connected BCL 80 can be exchanged without difficulty since all parameters are maintained.

### 7.3.1 Service Operating Mode

Setting the required parameters is carried out easiest in the 'service' operating mode.

#### Terminal Interface

By switching the operating mode switch from operation (setting 2) to service (setting 1), the connection to the host computer is broken and the RS 232 service interface is activated. The MA 10 offers a service interface for commissioning the read station in a network. The interface consists of a 9 pin SubD connector (male) and can be reached by removing the housing cover on the MA 10.

#### Connection

A PC or terminal can be connected to the MA 10 via the RS 232/V.24 serial interface and used to set the parameters of the BCL 80. The connection is made using a crossed RS 232 connection cable that establishes the RxD, TxD and GND connections. The hardware handshake at the service interface is via RTS. A CTS handshake is not supported.

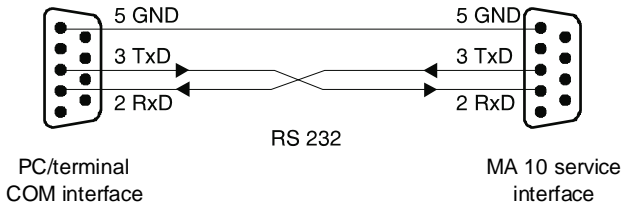

Figure 7.3: Connecting the service interface to a PC or terminal

See Figure 7.1 "Control elements of the MA 10".

Communication to the host computer via the host interface is no longer possible.

**Note!**

Switching to service mode results in a pre-set transfer protocol with the following parameters:

- transfer rate 9600 baud
- no parity
- 8 data bits
- 1 stop bit
- prefix: STX
- postfix: CR, LF

Construction of the data frame at the service interface				
	Prefix	Data	Terminator 1	Terminator 2
ASCII	STX	e.g.: 'CODE'	CR	LF
HEX	02h	43h 4Fh 44h 45h	0Dh	0Ah

**Wiring description**

The 9 pin SubD RS 232 Terminal connector (male) has the following pin assignments:

Pin 1	NC	not used
Pin 2	RXD	receive signal of the RS 232 service interface
Pin 3	TXD	transmit signal of the RS 232 service interface
Pin 4	NC	not used
Pin 5	GND	signal reference potential 0 V DC
Pin 6	NC	not used
Pin 7	RXD_Host	receive signal of the host interface
Pin 8	NC	not used
Pin 9	reserved	for service purposes only

Using a PC and a terminal program, the setup program of the BCL 80 can be called, online commands sent and data received via this interface terminal.



**Note!**

*In setting 2 ('operation') of the operating mode switch, the terminal connector can be used as a data monitor. In this case, data sent from the BCL 80 (jumper in Figure 7.1 in upper position) or data received from host (jumper in Figure 7.1 in lower position) can be logged. The data protocol is set by the host interface in the latter case.*

**Configuration software**

Leuze offers a convenient configuration program 'BCL Config' for setting the required device parameters (see Chapter 5 "Accessories / Order Designation").

### 7.3.2 Setting Parameters 'Offline' (Loading)

#### *Setting parameters*

The parameters are programmed on a PC without direct connection to the BCL 80 ('Offline' programming) and saved in a file (parameter file).

#### *Downloading parameters*

After successful programming, the parameters are loaded into the BCL 80 (parameter 'Download').

This causes the required parameters to be transferred from the host computer, or a computer connected to the interface terminal of the MA 10, to the BCL 80 or MA 10, respectively. If the same parameters are to be loaded into several devices, parameter download is the most efficient method.

Leuze electronic offers the configuration and terminal program 'BCL-Config' with which parameter sets can be easily loaded, changed and stored.

See Chapter 5 "Accessories / Order Designation".

Detailed information concerning customer-specific applications can be requested from Leuze sales and service offices.

A description of the parameters that can be set using the configuration program can be found in Chapter 9.

### 7.3.3 Setting Parameters 'Online'

The other possibility for setting the required operating parameters of the BCL 80 is through 'Online' programming via the integrated, two-language setup program (English, German) in the BCL 80.

#### *Setup program*

Using a PC (notebook) connected to the interface terminal, the menu-driven setup program can be called while in the service operating mode.

'Online' commands can then be directly entered that query data or carry out a software reset.

Communication is carried out using a terminal program or more conveniently using the Leuze configuration program.

A detailed description of the setup program along with all parameters which can be set, as well as the most important 'Online' commands can be found in Chapter 9.

### 7.3.4 Setting the Bar Code Parameters Using 'autoConfig'

The parameters of the bar codes which are to be read can be easily set using the function 'autoConfig'. In order to check the programmed bar codes, the BCL 80 should be connected to a data terminal. The detection of the desired bar code(s) can be checked on the terminal.

#### **Manual or 'Online' activation**

- The 'autoConfig' function is activated on the MA 10 using DIP switch 2 (see Fig. 7.1 for the location of the DIP switch).
- The 'autoConfig' function can be activated and deactivated via the serial interface (host or service interface) using the 'Online' commands 'CA+' (activate) and 'CA-' (deactivate).

Details of 'Online' commands can be found in Chapter 9.

If 'autoConfig' is active, the ERR LED and RDY LED on the MA 10 alternately blink.

#### **Setting parameters**

After activating the 'autoConfig' function, the BCL 80 can read from one to eight example labels containing the bar codes which are to be read. The BCL 80 decodes the labels and displays, via the interface, the code type, the number of decoded characters and the character itself.

#### **Number of labels to be decoded**

While 'autoConfig' is active, have the BCL 80 read as many labels in row as it will later during a reading cycle when in normal operation. The number of labels can be set from 'Set Code' in the submenu 'Decoding' of the setup program. The number of labels is limited to 8 when using the 'autoConfig' function.

#### **Code type and No. of characters of the label to be decoded**

The BCL 80 evaluates the number of labels, and at the same time, the code type and number of characters. This corresponds to the programming of the code types in the submenu 'Decoding / Select Code Type' of the setup program.

#### **Normal state of the MA 10 switched input SE1**

The state (high or low) which is present at the switched input SE1 while the 'autoConfig' function is active is taken as the new normal state for this switched input. This corresponds to the function 'Inversion' in the submenu 'Switched Inputs and Outputs / Switched Input Decoding (S1)' of the setup program.

#### **Store parameters**

When the 'autoConfig' function is deactivated, the programmed parameters are stored and copied into the current parameter set.

**Before** deactivating the 'autoConfig' program, please remove any labels from the scanning area of the BCL 80 since the new code parameters otherwise will not be stored properly.

## 8 Operation

### 8.1 Display Elements

On the back side of the MA 10, there are 4 LEDs which display the momentary operating status

LED	Colour	Meaning
RDY	green	Ready
ERR	yellow	Error
ACT	red	Scanner active
DEC	green	Decoding successful

#### Status conditions of the LEDs



All four LEDs illuminate

- for approx. 0.5 second after connecting the operating voltage.
- after accepting a 'cold start' reset (> 4 s) up until the reset button is released.

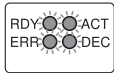

All four LEDs blink

- if the connection between the MA 10 and BCL 80 is interrupted.



RDY blinks

- during the 'Power On' function test.



RDY illuminates

- when the devices are ready.



ERR illuminates

- if a hardware error is encountered after the initialisation phase or in the case of a serious software error.

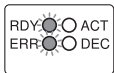

RDY and ERR blink simultaneously

- when the setup program is activated. Notice: No read operations can be carried out.



RDY and ERR blink alternately

- when the 'autoConfig' function is activated by setting the corresponding DIP switch.
- when a reference code is defined (Teach-In).



ACT illuminates

- while the scanner is active, i.e. when the laser is in operation.

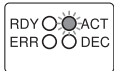

ACT blinks

- if a warning is output during the 'autoControl' function.



DEC illuminates

- for approx. 0.5 second after successfully completing a decoding process.

## 8.2 Important Functions During Operation

The BCL 80 has a function which automatically monitors the reading quality as well as the quality of the bar code label.

### ***'autoControl' function***

When the 'autoControl' function is active, the BCL 80 constantly compares the total number of scans with the number of decoded scans. If the number of decodable scans falls below a user defined percent of the total scans, the MA 10 outputs a warning:

- the ACT LED blinks.
- a warning symbol can be output to the host.
- a switched output can be controlled.

A detailed description of all adjustable parameters can be found in Chapter 9.

## 8.3 Error Handling

Errors are visibly indicated on the MA 10 via the ERR LED (see Chapter 7.2).

Further error, warning and status messages are transferred via the host interface or the terminal interface.

### ***Types of errors***

Errors are divided up into the following types.

- Warnings
- Serious errors

### ***Warnings***

Warnings indicate temporary operating faults which do not effect the proper functioning of the device.

### ***Serious errors***

Serious errors impair the proper functioning of the device. The device must be reinitialised.

### ***Troubleshooting***

Isolated warnings can be ignored, since the BCL will continue to function properly.

After a serious error has occurred, you should reboot the system. The BCL will be reinitialised and should then function properly again. If a hardware problem is present, the BCL 80 will not reinitialise.

If you are still unable to eliminate faults and errors, contact your local Leuze service office (addresses can be found on the back page of this operating manual).

## 9 Configuration

### 9.1 Overview of Commands and Parameters

'Online' commands can be used to send commands directly to the device for diagnosis and configuration. In order to use this feature, the BCL 80 /MA 10 must be connected to a host or service computer via the serial interface. The commands can be sent either via the host or the service interface.

Be sure that both data devices are set to the same protocol:

- service interface: 9600 Baud, 8-None-1
- host interface: protocol configured by user

#### ***'Online' commands***

With the commands, you can

- call the setup program.
- carry out a software reset in order to reinitialise the device.
- call up error messages.
- call up statistical device information.
- internally copy and test parameter sets.
- activate and test system components.

#### ***Syntax***

'Online' commands consist of one or two ASCII characters followed by command parameters.

No separation characters may be entered between the command and the command parameter(s). Both small and capitalised letters can be used.

Example:

Command '**CA**': autoConfig function

Parameter '+': Active

Transmitted is: '**CA+**'

#### ***Notation***

Commands, command parameters and returned data are enclosed between single quotation marks ''.

Most online commands are acknowledged by the BCL 80 and any requested data returned. With commands that are not acknowledged, the results of carrying out the command can be observed or checked directly at the device.

### 9.1.1 General 'Online' Commands

#### Software version number

<b>Command</b>	'V'
Description	Requests information about the software version
Parameter	none
Acknowledgement	'BCL 80' 'V 50.13' '22.06.97' 'MA 10' (only when a connector unit MA 10 is installed) 'V 01.07' The device type appears in the first line followed by the software version number and date. The device type on the connector unit appears on the fourth line followed by the version number (the dates may be different than those shown here).



**Note!**

Using this command, you can check whether the connected host or service computer is properly connected and configured. If an acknowledgement is not received, then the interface connections, protocol and service switch must be checked.

#### Software reset

<b>Command</b>	'H'
Description	Carries out a software reset. The device is restarted and reinitialised, leaving it in the same state as when the supply voltage is switched on.
Parameter	none
Acknowledgement	'S' (Start character)

#### Call the setup program

<b>Command</b>	'E'
Description	Calls the setup program. The main menu of the setup program is displayed.
Parameter	none
Acknowledgement	'Load Parameter Set' ' ' ' Setup' '-----' ' 1: Language' ' 2: Decode Setup' ' ' 'Enter:'



**Note!**

Read/write operations cannot be carried out in the service mode. The setup program must always be ended (see Chapter 9.2.1), in order to return to normal operation.

*'autoConfig'*

Command	'CA'
Description	Activates or deactivates the 'autoConfig' function. Certain label reading parameters are programmed automatically in the setup by the labels which are read while the 'autoConfig' function is active (see also Chapter 7.3.4).
Parameter	'+' activates 'autoConfig' '/' rejects the last code read '-' deactivates 'autoConfig' and stores the decoded data in the current parameter set.
Acknowledgement	xx yy zzzzzz (only with 'CA+')
Description	xx Code type of the read code 01 = 2/5 Interleaved 02 = Code 39 03 = 2/5 IATA 04 = 2/5 INDUSTRIAL 06 = UPC (A,E) 07 = EAN 08 = Code 128 / EAN 128 09 = Pharmacode 10 = Add-On (EAN / UPC) 11 = CODABAR yy No. of digits of the read code zzzzz Contents of the decoded label. The ↑ appears if the label was not correctly read.

**Reference code**

Command	'RS'
Description	This command can be used to define a new reference code in the BCL 80 by means of direct entry via the serial interface. The data are saved in the parameter set according to their input under reference code 1 or 2 and stored in the working buffer for further processing. See Chapter 9.2.7 for reference codes.
Parameter	RSyxxzzzzzz y, x and z are place holders (variables) for the actual input. 'y' def. Reference code No. = '1' (Code 1) '2' (Code 2) 'xx' def. Code type ( '01', '02', '03', '04', '06', '07', '08', '09', '10', '11', as above) 'z' def. Code information (1 ... 31 characters)
Acknowledgement	no
Example	input = 'RS10678654331' [Code 1 (1), UPC (06), 78654331]

**Teach-In**

Command	'RT'
Description	This command enables a reference code to be defined quickly by reading an example label. See Chapter 9.2.7 for reference codes.
Parameter	'1' defines reference code 1 '2' defines reference code 2 '-' Exit the Teach-In process
Acknowledgement	zzzzzz Contents of the decoded label



**Note!**

*With this function, only code types are recognised that are identified using the 'autoConfig' function or which were set in the setup.  
After each reading via a 'RT1' or 'RT2' command, explicitly switch off the function again using the 'RT-' command since failure to do so will interfere with other commands as well as prevent execution of a new 'RT1' or 'RT2' command.*

**Code recognition**

Command	'CC'
Description	Reads the code type and contents of an unknown label <b>without</b> storing it in Setup.
Parameter	none
Acknowledgement	xx yy zzzzzz
Description	The acknowledgement is the same as that of the 'autoConfig' function.

### 9.1.2 'Online' Commands for System Control

#### *Activate sensor input 1*

<b>Command</b>	'+'
Description	Activates decoding (sensor input 1). A signal can be simulated on sensor input 1 with this command.
Parameter	none
Acknowledgement	none

#### *Deactivate sensor input 1*

<b>Command</b>	'-'
Description	Deactivates decoding (sensor input 1). A signal can be simulated on sensor input 1 with this command.
Parameter	none
Acknowledgement	none

#### *Activate sensor input 2*

<b>Command</b>	','
Description	Activates the definition of reference code 1 (sensor input 2). A signal can be simulated on sensor input 2 with this command.
Parameter	none
Acknowledgement	none

#### *Deactivate sensor input 2*

<b>Command</b>	','
Description	Deactivates the definition of reference code 1 (sensor input 2). A signal can be simulated on sensor input 2 with this command.
Parameter	none
Acknowledgement	none

**9.1.3 'Online' Commands for System Testing**

*Diagnosis laser*

<b>Command</b>	<b>'DL'</b>
Description	Controls and tests the laser diode in the device.
Parameter	'+' switches on the laser diode. '-' switches off the laser diode. 'C' outputs the laser current.
Acknowledgement	no 'DS33' : invalid parameter for the command 'DL' 'DS34': invalid command length 'DLCyyy'
Description	yyy is the laser current in mA

*Diagnosis motor*

<b>Command</b>	<b>'DMS'</b>
Description	Returns the rotary frequency of the polygon mirror wheel drive motor.
Parameter	none
Acknowledgement	'DMSxxxx'
Description	xxxx is the current rotary frequency of the motor in revolutions/minute.

*Supply voltage*

<b>Command</b>	<b>'DUV'</b>
Description	Returns the supply voltage of the BCL 80.
Parameter	none
Acknowledgement	'DUVxx.x'
Description	xx.x is the current supply voltage in V.

### 9.1.4 'Online' Commands for Querying Statistical Data

#### Query device statistics

Command	'SR'
Description	Returns the current contents of the given field of the statistical device data memory.
Parameter	'00' to '19'
Acknowledgement	'ST00XXXXX' to 'ST19XXXXX'
Description	<p>'ST00XXXXX': XXXXX is the length of time in seconds that the laser diode has been switched on since the last initialisation</p> <p>'ST01XXXXX': XXXXX is the length of time in minutes that the polygon wheel motor has been switched on since the last initialisation</p> <p>'ST05XXXXX': XXXXX the number of correctly received commands via the interface</p> <p>'ST06XXXXX': XXXXX the number of incorrectly received commands via the interface</p> <p>'ST07XXXXX': XXXXX the number of sent commands via the interface that have received positive acknowledgement</p> <p>'ST08XXXXX': XXXXX the number of sent commands via the interface that have received negative acknowledgement</p> <p>'ST09XXXXX': XXXXX the number of correctly received commands via the host</p> <p>'ST10XXXXX': XXXXX the number of incorrectly received commands via the host</p> <p>'ST11XXXXX': XXXXX the number of sent commands via the host that have received positive acknowledgement</p> <p>'ST12XXXXX': XXXXX the number of sent commands via the host that have received negative acknowledgement</p> <p>'ST13XXXXX': XXXXX the number of recorded read processes since the last read enable</p> <p>'ST14XXXXX': XXXXX the number of read labels since the last reset</p> <p>'ST15XXXXX': XXXXX the number of read labels since the last read enable</p> <p>'ST16XXXXX': XXXXX the number of read labels from the last scan</p> <p>'ST17XXXXX': XXXXX is the number of read enables since the last reset</p> <p>'ST18XXXXX': XXXXX the number of correctly decoded labels since the last reset</p> <p>'ST19XXXXX': XXXXX the number of incorrectly decoded labels since the last reset</p>

### 9.1.5 'Online' Commands for Parameter Set Operations

#### Test parameter set

Command	'PA'
Description	Tests the given parameter set for validity using a checksum.
Parameter	'0' tests the current parameter set. '1' tests the customer-specific parameter set (MA 10 only).
Acknowledgement	all possible acknowledgements are listed below.

#### Copy parameter set

Command	'PC'
Description	Copies the given source parameter set into the given target parameter set
Parameter Example	<b>BCL 80 Stand alone:</b> '0' current parameter set. '2' parameter set with factory default settings. 'PC20': Reset to factory default settings
Parameter Examples	<b>BCL 80 with MA 10:</b> '0' current parameter set. '1' customer-specific parameter set. '2' parameter set with factory default settings. 'PC20': Reset to factory default settings 'PC01': The current parameter set is copied in the customer-specific parameter set (backup) 'PC10': Reset to customer-specific settings
Acknowledgement	all possible acknowledgements are listed below.

#### Possible acknowledgements

Acknowledgement	Description
'PS0'	valid parameter set
'PS1'	invalid message
'PS2'	invalid message length
'PS3'	invalid type of BCC check sum
'PS4'	invalid BCC check sum
'PS5'	invalid length of data
'PS6'	invalid message parameters
'PS7'	invalid start address in parameter set
'PS8'	invalid CRC check sum of parameter set
'PS9'	invalid type of parameter set



**Note!**

A valid parameter set operation must be acknowledged with 'PS0'. Should an error occur, the command should be repeated. Repeated error acknowledgements indicate an error in the parameter set. If in doubt, contact your Leuze sales or service office (see back page for addresses).

9.1.6 'Online' Commands for BCL 80 with Oscillating Mirror



**Attention!**

The 'PT' command lets you change the parameter set in a way that may render it useless. Make sure that you only use parameter numbers and ranges that have been described here.

**Transmit parameters**

Command	'PT'
Description	This command permits the programming of arbitrary reading areas. They can be selected during operation. The scan area can be adapted to any application.
Parameter	<p>PT000xxxxy</p> <p>x and y are variables that are to be replaced with the actual input.</p> <p>'xxx' defines the parameter number (384, 386, 387, 388, 389)</p> <p>'yy' defines the range for the parameter (in hexadecimal)</p> <p><b>384</b> = mode of mirror oscillation (00h ... 02h)</p> <p><b>00 (mode 0)</b> when activated the oscillating mirror moves from start to stop position</p> <p><b>01 (mode 1)</b> when activated the oscillating mirror moves from start to stop position and back</p> <p><b>02 (mode 2)</b> when activated the oscillating mirror moves permanently between start and stop position</p> <p><b>386</b> = time interval for forward movement (02h ... 5Fh) selectable in 50 ms steps, e.g.</p> <p><b>03</b> corresponds to a forward movement time of 150 ms.</p> <p><b>02</b> is the smallest value = high osc. frequency (5 Hz)</p> <p><b>5F</b> is the highest value = low osc. frequency (0.1 Hz)</p> <p><b>387</b> = time interval for reverse movement (02h ... 5Fh), as 386.</p> <p><b>388</b> = start position of the oscillation movement(00h ... 5Fh)</p> <p><b>00</b> corresponds to +15° (see Chapter 4.3.3 "Reading Fields")</p> <p><b>389</b> = stop position of the oscillation movement (00h ... 5Fh)</p> <p><b>5F</b> corresponds to -20° (see Chapter 4.3.3 "Reading Fields")</p>
Acknowledgement	no
Example	<p>Input = 'PT00038402' (sets mirror into mode 2)</p> <p>Input = 'PT0003860A' (forward movement time 0Ah = 10 x 50 ms)</p> <p>Input = 'PT00038704' (reverse movement time 04h = 4 x 50 ms)</p> <p>Input = 'PT00038804' (start position 04h)</p> <p>Input = 'PT00038953' (stop position 53h)</p>



**Note!**

To change the default values, you may transmit one or more parameters in a string online to the scanner. A subsequent soft reset ('H' command) activates the new settings.

**Read parameters**

Command	'PR'
Description	The command shows the actual content of the given parameter number (see 'PT' command).
Parameter	PR00xxyyy x and y are variables that are to be replaced with the actual input. ' <b>xx</b> ' defines the number of the parameter to be read (384, 386, 387, 388, 389; see 'PT' command) ' <b>yyy</b> ' defines the number of bytes to be displayed; this should always be 001, such that only the desired value is displayed
Acknowledgement	' <b>xx</b> ' = current value from the parameter's range of values (e.g. 03h)
Example	Input = 'PR00387001' returns the value for the current setting of the reverse movement time (e.g. '0A')

## 9.2 Setup Program

### 9.2.1 Overview of the Parameter Structure

The setup program is menu driven and largely self-explanatory. Figure 9.1 displays an overview of the menu structure.

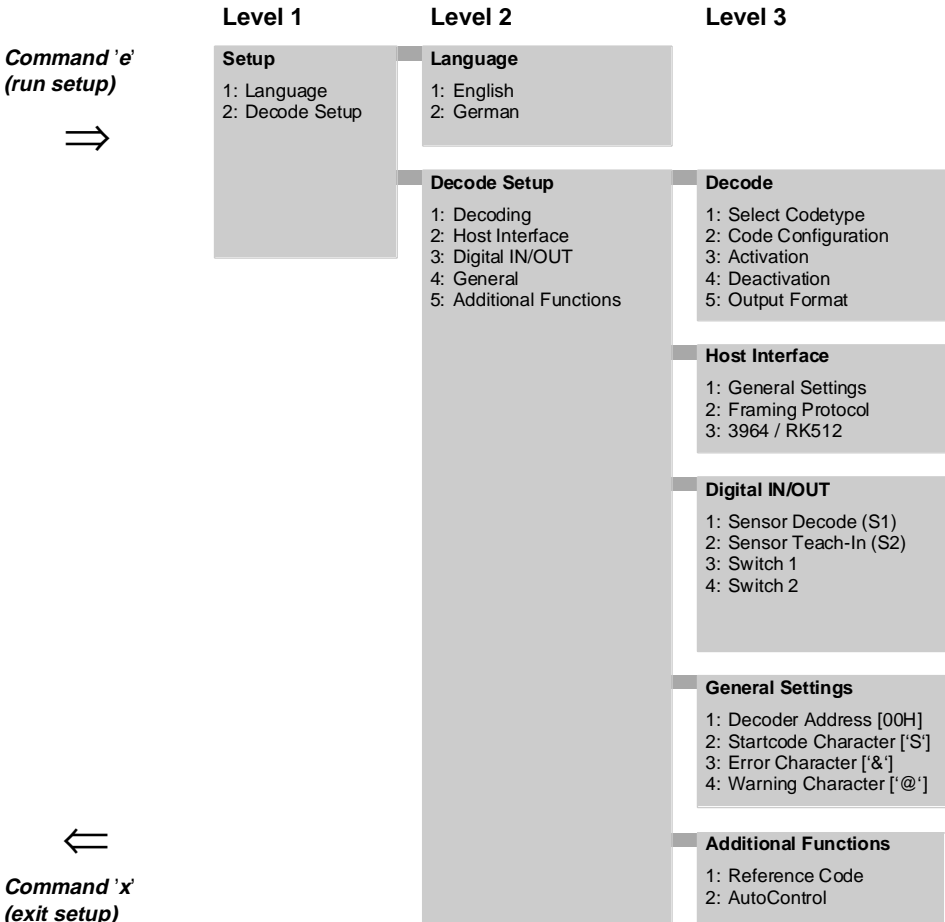

Figure 9.1: Overview of the parameter structure



**Note!**

The text of the setup program can be set to either German or English. The language is set to English in the factory default parameter set which is loaded when the device is commissioned.

Only the English version of the setup program is described below.

First change the language of the setup program to English as described below.

**Conventions**

- The **desired menu point** can be reached with '**Number**' + '**Enter**'.
- '**Esc**' takes you **back one level**.
- The '**space key**' moves you to the **next menu on the same level**.
- **Entries** must be confirmed with '**Enter**'. Character values are entered as described below:
  - decimal: **xx** where xx is the decimal code of the ASCII character
  - hexadecimal: **xxh** or **xxH** where xx is the hexadecimal code of the ASCII character
  - 'Character' input: '**xx**' where xx is the character itself

A complete ASCII table can be found in the appendix (Chapter 11.1).

- **Activated options** are indicated by a '**\***' in the menus.
- The currently **set character value** appears in **square brackets** '[ ]'.
- The **default values** and factory settings are marked *ITALIC* or listed in a default table and marked by '[ ]'. These values are valid when the device is shipped or after a 'cold-start' (RESET) to the factory settings.
- '**X**' **exits the setup program** independent of which level you are in. A menu will appear the following options:
  - Return: returns to the setup program
  - Quit: exits the setup program without saving any changes made to the parameter set
  - Save and Quit: saves the new settings in the current parameter set and exits the setup program.

## *Calling the setup program*

- Call the setup program using the 'Online' command 'E'.

The main menu appears:

```
'Load Parameter Set'
','
'  Setup'
'-----'
' 1: Language'
' 2: Decode Setup'
','
'Input:'
```

## *Select language*

- Enter '1' + 'Enter' to reach the menu 'Language'.

The current language is indicated by a '\*'.

- Enter '2' + 'Enter' to change the setup language to e.g. 'German'.

The setup program returns to the main menu.

## *Decode Setup*

- Enter '2' + 'Enter' in the main menu to reach the 'Reader Setup' menu.

The 'Reader Setup' menu appears:

```
'
','
'  Decode Setup'
'-----'
' 1: Decode'
' 2: Host Interface'
' 3: Digital IN/OUT'
' 4: General'
' 5: Additional Functions'
','
'Enter:'
```

The individual menu points of the 'Decode Setup' are described below.

### 9.2.2 Setting the Decoding Parameters

The following submenus can be selected under the 'Decode' menu of the Setup program:

- Select code type
- Code configuration
- Type of scanner activation
- Type of scanner deactivation
- Data output format

#### Select code type

You can select one or several of the following codes:

Code type No.	Code	Digits	Default
1	<i>*2/5 Interleaved</i>	2 ... 62	[10]
2	Code 39	1 ... 63	
6	UPC (A, E)	8 or 12	
7	EAN	8 or 138	
8	Code 128, EAN 12	1 ... 63	
9	Pharmacode	1 ... 63	
A	Add-on for EAN	2 or 5	
B	Codabar	1 ... 63	

- Selected codes are indicated by a '\*'. The set number of digits of the code is given in square brackets '[' ]'.
- Only labels which have the same code type and number of characters are recognised.
- Several numbers of characters and areas can be given.  
 Example: number of characters [10-14] = 10 to 14 characters  
 number of characters [10, 20] = 10 and 20 characters
- Always activate only those code types and number of characters that will actually be read.
- If you do not exactly know the code type and/or the number of characters, use the 'CC' (code detection) or 'CA' (autoConfig) function (see Chapter 9.1.1 "General 'Online' Commands").
- When using the 'Code 128, EAN 128', the number of read characters can deviate from the set number of characters in certain situations. Use the 'CA' or 'CC' command to avoid mistakes.
- A code type can be deselected by setting its number of characters to the value '0'.

## ***Code configuration***

The following settings can be made for the selected codes in the menu 'Code Configuration':

- The number of labels which are to be read during a read process.
- The number of equal scans for a read process, i.e. the number of times a label must be scanned and return the same code for it to be considered correctly read.

<b>Parameter</b>	<b>Valid range of values</b>	<b>Default</b>
Number of labels	1 ... 64	[1]
Equal scans	1 ... 255	[2]

## ***Activation***

You can set continuous read processes in the menu 'Activation' without a hardware sensor:

- Start a new read process after an adjustable delay time following the previous read process.
- Start a new read process immediately after the previous read process.

<b>Parameter</b>	<b>Valid range of values</b>	<b>Default</b>
Delay Time	0 ... 30 in 100 ms steps	[0]
Continuous	Yes, No	[No]

If 'Yes' is set under 'Continuous', the time set under 'Delay Time' will have no influence.

## ***Deactivation***

In the menu 'Deactivation', you can specify when a read process should be cancelled after failing to read a label:

- Cancel after a specified time from the beginning of the read process (Gate Time).
- Cancel after a specified number of unsuccessful scans.

<b>Parameter</b>	<b>Valid range of values</b>	<b>Default</b>
Max. Gate Time	0 ... 30 in 100 ms steps	[0]
Scans without Data	0 ... 255	[0]

If a value greater than 0 is given for both parameters, the read is cancelled by the first condition which is exceeded.

## ***Output formatting***

The menu 'Output Format' is more extensive and is therefore discussed later in its own section (see Chapter 9.2.3 "Setting the Output Format Parameters").



## Formatter modes output formatting

In the menu 'Formatter Modes', you can specify how the output of the decoded bar code data should be formatted:

- Select whether the data of all labels should be sent together in a single message or in individual messages.
- Select whether the data of each decoded label should be separated by a separator character.
- Select whether the data of the decoded label should be output to an even address (i.e. with an even number of bytes).
- Select whether the data of the decoded label should have the same length independent of the number of digits.

Parameter	Valid range of values	Default
All labels in a single message	Yes, No	[No]
Separate labels with separation character	Yes, No	[No]
Label output on even address	Yes, No	[No]
Equal length of labels	Yes, No	[No]



### **Note!**

*If all labels are to have the same length, then the length of all labels should agree with the length of the longest label. The unused digits of the smaller labels are then filled with separator characters.*

## Title Headers

Two title header texts can be specified in the menu 'Title Header':

- Header 1
- Header 2

Parameter	Valid range of values
Header 1	<i>Nothing</i> Title Header char 1 No. of Valid Labels No. of All Scans of the gate time
Header 2	<i>Nothing</i> Title Header char 1 No. of Valid Labels No. of All Scans of the gate time Other entries on request

**Label Headers**

Three headers can be specified in the menu 'Label Header':

- Label Header 1
- Label Header 2
- Label Header 3



**Note!**

*The Label Header Text Char 1 can be defined in the menu 'Output Constants'. The scan quality of the label is calculated from the number of valid decodings divided by the number of possible decodings in % (also valid for Label Footnote).*

<b>Parameter</b>	<b>Valid range of values</b>
Label Header 1	<p><i>Nothing</i></p> <p>Tag Header Char 1</p> <p>No. of Label</p> <p>Codetype</p> <p>Digits</p> <p>Label Quality</p>
Label Header 2	<p><i>Nothing</i></p> <p>Tag Header Char 1</p> <p>No. of Label</p> <p>Codetype</p> <p>Digits</p> <p>Label Quality</p>
Label Header 3	<p><i>Nothing</i></p> <p>Tag Header Char 1</p> <p>No. of Label</p> <p>Codetype</p> <p>Digits</p> <p>Label Quality</p> <p>Other entries on request</p>

**Label Footer**

Three footer texts can be specified in the menu 'Label Footer':

- Label Footer 1
- Label Footer 2
- Label Footer 3

<b>Parameter</b>	<b>Valid range of values</b>
Label Footer 1	<i>Nothing</i> Tag Header Char 1 No. of Label Codetype Digits Label Quality
Label Footer 2	<i>Nothing</i> Tag Header Char 1 No. of Label Codetype Digits Label Quality
Label Footer 3	<i>Nothing</i> Tag Header Char 1 No. of Label Codetype Digits Label Quality Other entries on request

### **Output constants**

Characters and texts can be entered from the menu 'Output Constants' for the following format characters:

- Title header character
- Label header text character 1
- Label separation character
- Good read character
- No read string

<b>Parameter</b>	<b>Valid range of values</b>	<b>Default</b>
Prefix Character	ASCII character	[00H]
Label Header Text Character 1	ASCII character	[00H]
Label Separator Character	ASCII character	[20H]
Good Read Char	ASCII character	[00H]
Text for unsuccessful scan	text string with up to 20 characters	[18H]



**Note!**

*The characters can be entered as decimal code, hexadecimal code or as a character. Characters set to '00H' are not output!*

### 9.2.4 Setting the Host Interface Parameters

The following submenus can be selected in the menu 'Host Interface' of the Setup program:

- General Settings
- Framing Protocol
- 3964 / RK 512 Protocol

#### General Settings

In the menu 'General Settings', the parameters are entered for the serial transfer to the host:

- Data format
- Baud rate
- Protocol
- Handshake Mode

Parameter	Valid range of values		
Data Format	7 Bit,	no parity,	2 stop bits
	7 Bit,	even parity,	1 stop bit
	7 Bit,	even parity,	2 stop bits
	7 Bit,	odd parity,	1 stop bit
	7 Bit,	odd parity,	2 stop bits
	<i>8 Bit,</i>	<i>no parity,</i>	<i>1 stop bit</i>
	8 Bit,	no parity,	2 stop bits
	8 Bit,	even parity,	1 stop bit
	8 Bit,	even parity,	2 stop bits
	8 Bit,	odd parity,	1 stop bit
	8 Bit,	odd parity,	2 stop bits
	9 Bit,	no parity,	1 stop bit
		multiNet mode	
Baudrate	110	baud	
	300	baud	
	600	baud	
	1200	baud	
	2400	baud	
	4800	baud	
	<i>9600</i>	<i>baud</i>	
	19200	baud	
	38400	baud	
57600	baud		

<b>Parameter</b>	<b>Valid range of values</b>
Protocol	No protocol <i>Protocol Frame</i> Protocol frame with acknowledge 3964 / RK 512 Protocol multiNet Plus slave
Handshake Mode	<i>No Handshake</i> RTS RTS / CTS RTS / CTS ; TX active Half duplex XON / XOFF

### ***Framing Protocol***

The following parameters for transfer to the host can be set in the menu 'Framing Protocol':

- Prefix 1 (title header character)
- Prefix 2 (title header character)
- Postfix 1 (title footer character)
- Postfix 2 (title footer character)
- Address Format
- BCC Mode (Block Check Character)

<b>Parameter</b>	<b>Valid range of values</b>	<b>Default</b>
Prefix 1	00h ... FFh	[02h]
Prefix 2	00h ... FFh	[00h]
Postfix 1	00h ... FFh	[0Dh]
Postfix 2	00h ... FFh	[0Ah]
Address Format	<i>No Address</i> Binary address ASCII address	
BCC-Mode	<i>No BCC</i> BCC mode 1 BCC mode 2 BCC mode 3	

More detailed information concerning the BCC modes is available on request.



***Note!***

*If the BCL 80 should operate 'stand alone' as a slave in the multiNet, then the following settings are required:*

***Data format:*** multiNet mode  
***Baud rate:*** 57600 baud    ***Protocol:*** MultiNet Plus slave  
***Handshake:*** none         ***Address format:*** ASCII address

**3964 / RK 512 Protocol**

The BCL 80 / MA 10 can be operated with the procedure 3964 / RK 512. For this the option '3964 / RK 512 protocol' must be activated in the menu 'General Settings / Protocol'. The required parameters are set in the menu '3964 / RK 512'. The following operating modes are possible:

- 3964
- 3964 R
- 3964 / RK 512

Parameter	Valid range of values	Default
use BCC within 3964	Yes, No	[No]
transmit with high priority	Yes, No	[No]
character receive timeout	0 ... 3000 ms	[220]
acknowledge receive timeout	0 ... 3000 ms	[550]
no. of retransmissions	0 ... 255	[5]
use RK 512	Yes, No	[No]
no. of data module	0 ... 255	[10]
start address within module	0 ... 255	[0]
address offset of slave	0 ... 255	[64]
use reaction telegr. in RK 512	Yes, No	[No]

**9.2.5 Setting the Parameters of the Digital IN/OUT**

The following submenus can be selected from the menu 'Digital IN/OUT':

- Sensor Decode (S1)
- Sensor Teach In (S2)
- Switch 1
- Switch 2

**Sensor Decode (S1)**

The switching parameters of this input can be entered in the menu 'Sensor Decode (S1)':

- Debounce Time
- Delay Off
- Inversion

Parameter	Valid range of values	Default
Debounce Time	0 ... 255 ms	[5]
Delay Off	0 ... 2500 ms	[0]
Inversion	Yes, No	[No]

## Sensor Teach In (S2)

The switching parameters of this input can be entered in the menu 'Sensor Teach-In (S2)':

- Debounce Time
- Delay Off
- Inversion

Parameter	Valid range of values	Default
Debounce time	0 ... 255 ms	[5]
Delay Off	0 ... 2500 ms	[0]
Inversion	Yes, No	[No]



### **Note!**

*When using switches with contact bounce (e.g. relay contacts) set the end bounce time high (between 50 and 255 ms), since contact bounce can cause multiple switching impulses and interfere with the BCL software.*

## Switch 1

The switching parameters of this output can be entered in the menu 'Switch 1':

- Enable
- Activation
- Inversion

Parameter	Valid range of values	Default
Enable	Yes, No	[Yes]
Activation	Good Read Bad Read Start Reading Stop Reading Device Ready autoControl Reference code 1 Reference code 2	
Inversion	Yes, No	[No]

**Switch 2**

The switching parameters of this output can be entered in the menu 'Switch 2':

- Enable
- Activation
- Inversion

Parameter	Valid range of values	Default
Enable	Yes, No	[No]
Activation	<i>Good Read</i> Bad Read Start Reading Stop Reading Device Ready autoControl Reference code 1 Reference code 2	
Inversion	Yes, No	[No]

**9.2.6 Setting the General Parameters**

**Generals**

The following parameters can be set in the menu 'Generals' of the setup program:

- Decoder address:  
 A decoder address must be set if the BCL 80 is to be operated **without** an MA 10 in the multiNet, thus no address switch is available. Here the option 'Host interface / frame protocol / ASCII address' must be activated. The hardware switch has priority when operating with an MA 10.
- Startcode character
- Error character
- Warning character

Parameter	Valid range of values	Default
Decoder address	00h ... 1Fh	[00h]
Startcode character	00h ... 7Ah	['S']
Error character	00h ... 7Ah	['&']
Warning character	00h ... 7Ah	['@']

### 9.2.7 Additional Functions: Setting the Reference Code Parameters

The following submenus can be selected from the submenu 'Reference Code' under the menu 'Additional Functions':

- Code 1
- Code 2
- Don't care i.e. two reference codes can be defined and particular characters hidden.

#### Code 1 and Code 2

The following can be defined for code 1 and code 2:

- The content of the label to be read
- The code type of the label to be read
- Comparison operations which activate switch 1 or 2

Parameter	Valid range of values	Default
Code information	contents of the label to be detected	[ ' ' ]
Code type selection	code types that can also be set as decoding parameters	[ 'none' ]
Compare Mode	<i>No compare</i> Equal Unequal	

Settings for 'Comparison mode'

**no comparison:** deactivates the reference code detection,

**equal:** activates the set switching output when detected code and reference code are equal,

**unequal:** activates the set switching output when detected code and reference code are not equal

The assignment of switching output 1/2 to reference code 1/2 is set in the menu 'Switching inputs/outputs / Switching output 1/2 / Activation'.

#### Don't care

In order to allow the comparison of several similar labels, a 'Don't Care' character can be defined. The character is not permanently defined, thus giving the user the greatest flexibility when defining the reference code. It should be defined so that it does not occur in the code which will be read.

Parameter	Valid range of values	Default
Definition Mode	Yes, No	[No]
Don't Care Character	any ASCII character	[ '* ]

Settings for 'Override mode'

**Yes:** When a reference code is defined, the 'Don't care' character is taken into account

**No:** When a reference code is defined, the 'Don't care' character is not taken into account

**Example:** Code 1: Code Info: 1234\*\*\*\*

By setting the 'Don't-Care' character, the affected positions are "ignored", i.e. they are not relevant to the code comparison.

### 9.2.8 Additional Functions: Setting the 'autoControl' Parameters

The following submenus can be selected from the submenu 'autoControl' under the menu 'Additional Functions':

- Enable
- Limit Scan Quality
- Send Warning to Com
- Character for AutoControl warning

#### ***Enable***

Specify here whether the autoControl function is activated.

<b>Parameter</b>	<b>Valid range of values</b>	<b>Default</b>
Enable	Yes, No	[No]

#### ***Limit Scan Quality***

The scan quality is defined as the relationship between the number of decodable scans to the total number of possible scans. A threshold in percent can be entered here. If the percent of successful scans falls below this limit, a warning message will be sent and, if enabled, a switched output can be activated.

<b>Parameter</b>	<b>Valid range of values</b>	<b>Default</b>
Limit Scan Quality	0 ... 100 in %	[50]

#### ***Send Warning to Com***

Specify here whether a warning message should be output over the serial interface if the scan quality falls below the given value.

<b>Parameter</b>	<b>Valid range of values</b>	<b>Default</b>
Send warning to com	Yes, No	[No]

#### ***Character for AutoControl warning***

Define here the warning character which will be sent out over the serial interface if the scan quality falls below the given limit. It can be any ASCII character.

<b>Parameter</b>	<b>Valid range of values</b>	<b>Default</b>
Character for AutoControl warning	all ASCII characters 00: no output via the serial interface	[!]

## 10 Maintenance

### 10.1 General Maintenance Information

The bar code reader BCL 80 and the connector unit MA 10 normally should not require any maintenance by the user.

#### ***Cleaning***

Should it become soiled, clean the glass window of the BCL 80 with a soft cloth.



#### ***Attention***

*Do not use aggressive cleaning agents such as thinner or acetone for cleaning the device.*

### 10.2 Repair, Service

Repairs to the device must only be carried out by the manufacturer.

For repairs, contact your Leuze sales or service office. The addresses can be found on the back page of this operating manual.

# 11 Appendix

## 11.1 ASCII Table

ASCII	Dec.	Hex.	Oct.	Symbol	German
NUL	0	00	0	NULL	Null
SOH	1	01	1	START OF HEADING	Kopfzeilenbeginn
STX	2	02	2	START OF TEXT	Textanfangszeichen
ETX	3	03	3	END OF TEXT	Textendenzeichen
EOT	4	04	4	END OF TRANSMISSION	Ende der Übertragung
ENQ	5	05	5	ENQUIRY	Aufforderung zur Datenübertrag.
ACK	6	06	6	ACKNOWLEDGE	Positive Rückmeldung
BEL	7	07	7	BELL	Klingelzeichen
BS	8	08	10	BACKSPACE	Rückwärtsschritt
HT	9	09	11	HORIZONTAL TABULATOR	Horizontal Tabulator
LF	10	0A	12	LINE FEED	Zeilenvorschub
VT	11	0B	13	VERTICAL TABULATOR	Vertikal Tabulator
FF	12	0C	14	FORM FEED	Seitenvorschub
CR	13	0D	15	CARRIAGE RETURN	Wagenrücklauf
SO	14	0E	16	SHIFT OUT	Dauerumschaltungszeichen
SI	15	0F	17	SHIFT IN	Rückschaltungszeichen
DLE	16	10	20	DATA LINK ESCAPE	Datenübertragungsumschaltung
DC1	17	11	21	DEVICE CONTROL 1 (X-ON)	Gerätesteuerzeichen 1
DC2	18	12	22	DEVICE CONTROL 2 (TAPE)	Gerätesteuerzeichen 2
DC3	19	13	23	DEVICE CONTROL 3 (X-OFF)	Gerätesteuerzeichen 3
DC4	20	14	24	DEVICE CONTROL 4	Gerätesteuerzeichen 4
NAK	21	15	25	NEGATIVE ACKNOWLEDGE	Negative Rückmeldung
SYN	22	16	26	SYNCHRONOUS IDLE	Synchronisierung
ETB	23	17	27	END OF TRANSMISSION BLOCK	Ende d. Datenübertragungsblocks
CAN	24	18	30	CANCEL	Ungültig
EM	25	19	31	END OF MEDIUM	Ende der Aufzeichnung
SUB	26	1A	32	SUBSTITUTE	Substitution
ESC	27	1B	33	ESCAPE	Umschaltung
FS	28	1C	34	FILE SEPARATOR	Hauptgruppentrennzeichen
GS	29	1D	35	GROUP SEPARATOR	Gruppentrennzeichen
RS	30	1E	36	RECORD SEPARATOR	Untergruppentrennzeichen
US	31	1F	37	UNIT SEPARATOR	Teilgruppentrennzeichen
SP	32	20	40	SPACE	Leerzeichen
!	33	21	41	EXCLAMATION POINT	Ausrufungszeichen
"	34	22	42	QUOTATION MARK	Anführungszeichen
#	35	23	43	NUMBER SIGN	Nummerzeichen
\$	36	24	44	DOLLAR SIGN	Dollarzeichen
%	37	25	45	PERCENT SIGN	Prozentzeichen
&	38	26	46	AMPERSAND	Kommerzielles UND-Zeichen
'	39	27	47	APOSTROPHE	Apostroph
(	40	28	50	OPENING PARENTHESIS	runde Klammer (offen)
)	41	29	51	CLOSING PARENTHESIS	runde Klammer (geschlossen)
*	42	2A	52	ASTERISK	Stern

ASCII	Dec.	Hex.	Oct.	Symbol	German
+	43	2B	53	PLUS	Pluszeichen
,	44	2C	54	COMMA	Komma
-	45	2D	55	HYPHEN (MINUS)	Bindestrich (Minuszeichen)
.	46	2E	56	PERIOD (DECIMAL)	Punkt
/	47	2F	57	SLANT	Schrägstrich (rechts)
0	48	30	60	0	Zahl
1	49	31	61	1	Zahl
2	50	32	62	2	Zahl
3	51	33	63	3	Zahl
4	52	34	64	4	Zahl
5	53	35	65	5	Zahl
6	54	36	66	6	Zahl
7	55	37	67	7	Zahl
8	56	38	70	8	Zahl
9	57	39	71	9	Zahl
:	58	3A	72	COLON	Doppelpunkt
;	59	3B	73	SEMI-COLON	Semikolon
<	60	3C	74	LESS THEN	Kleiner als
=	61	3D	75	EQUALS	Gleichheitszeichen
>	62	3E	76	GREATER THEN	Größer als
?	63	3F	77	QUESTION MARK	Fragezeichen
@	64	40	100	COMMERCIAL AT	Kommerzielles a-Zeichen
A	65	41	101	A	Großbuchstabe
B	66	42	102	B	Großbuchstabe
C	67	43	103	C	Großbuchstabe
D	68	44	104	D	Großbuchstabe
E	69	45	105	E	Großbuchstabe
F	70	46	106	F	Großbuchstabe
G	71	47	107	G	Großbuchstabe
H	72	48	110	H	Großbuchstabe
I	73	49	111	I	Großbuchstabe
J	74	4A	112	J	Großbuchstabe
K	75	4B	113	K	Großbuchstabe
L	76	4C	114	L	Großbuchstabe
M	77	4D	115	M	Großbuchstabe
N	78	4E	116	N	Großbuchstabe
O	79	4F	117	O	Großbuchstabe
P	80	50	120	P	Großbuchstabe
Q	81	51	121	Q	Großbuchstabe
R	82	52	122	R	Großbuchstabe
S	83	53	123	S	Großbuchstabe
T	84	54	124	T	Großbuchstabe
U	85	55	125	U	Großbuchstabe
V	86	56	126	V	Großbuchstabe
W	87	57	127	W	Großbuchstabe
X	88	58	130	X	Großbuchstabe

ASCII	Dec.	Hex.	Oct.	Symbol	German
Y	89	59	131	Y	Großbuchstabe
Z	90	5A	132	Z	Großbuchstabe
[	91	5B	133	OPENING BRACKET	eckige Klammer (offen)
\	92	5C	134	REVERSE SLANT	Schrägstrich (links)
]	93	5D	135	CLOSING BRACKET	eckige Klammer (geschlossen)
^	94	5E	136	CIRCUMFLEX	Zirkumflex
_	95	5F	137	UNDERSCORE	Unterstrich
`	96	60	140	GRAVE ACCENT	Gravis
a	97	61	141	a	Kleinbuchstabe
b	98	62	142	b	Kleinbuchstabe
c	99	63	143	c	Kleinbuchstabe
d	100	64	144	d	Kleinbuchstabe
e	101	65	145	e	Kleinbuchstabe
f	102	66	146	f	Kleinbuchstabe
g	103	67	147	g	Kleinbuchstabe
h	104	68	150	h	Kleinbuchstabe
i	105	69	151	i	Kleinbuchstabe
j	106	6A	152	j	Kleinbuchstabe
k	107	6B	153	k	Kleinbuchstabe
l	108	6C	154	l	Kleinbuchstabe
m	109	6D	155	m	Kleinbuchstabe
n	110	6E	156	n	Kleinbuchstabe
o	111	6F	157	o	Kleinbuchstabe
p	112	70	160	p	Kleinbuchstabe
q	113	71	161	q	Kleinbuchstabe
r	114	72	162	r	Kleinbuchstabe
s	115	73	163	s	Kleinbuchstabe
t	116	74	164	t	Kleinbuchstabe
u	117	75	165	u	Kleinbuchstabe
v	118	76	166	v	Kleinbuchstabe
w	119	77	167	w	Kleinbuchstabe
x	120	78	170	x	Kleinbuchstabe
y	121	79	171	y	Kleinbuchstabe
z	122	7A	172	z	Kleinbuchstabe
{	123	7B	173	OPENING BRACE	geschweifte Klammer (offen)
	124	7C	174	VERTICAL LINE	Vertikalstrich
}	125	7D	175	CLOSING BRACE	geschweifte Klammer (zu)
~	126	7E	176	TILDE	Tilde
DEL	127	7F	177	DELETE (RUBOUT)	Löschen

Table 11.1: ASCII Table

## 11.2 Example Bar Code Label Types

### 11.2.1 Module 0.5

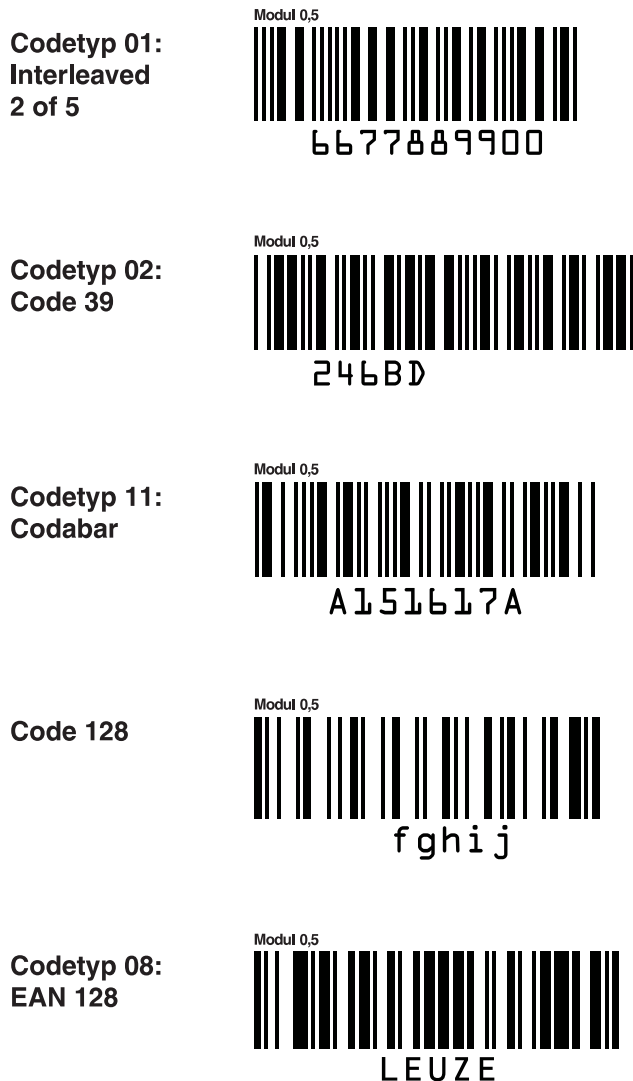

Figure 11.1: Barcode sample labels (module 0.5)

**Codetyp 06:  
UPC-A**



**Codetyp 07:  
EAN 8**



**Codetyp 10:  
EAN 13  
Add-on**

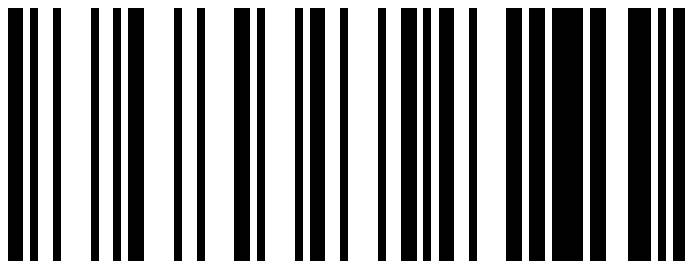

Figure 11.2: Barcode sample labels (module 0.5) - continued

11.2.2 Module 1.0

**Code 128**

Modul 1,0



abcde

**Code 39**

Modul 1,0

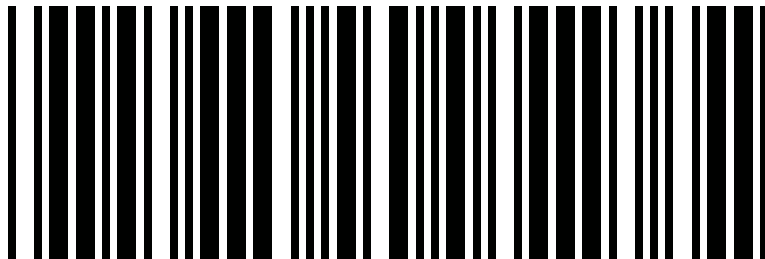

135AC

Figure 11.3: Barcode sample labels (module 1.0)

**Interleaved  
2 of 5**

Modul 1,0

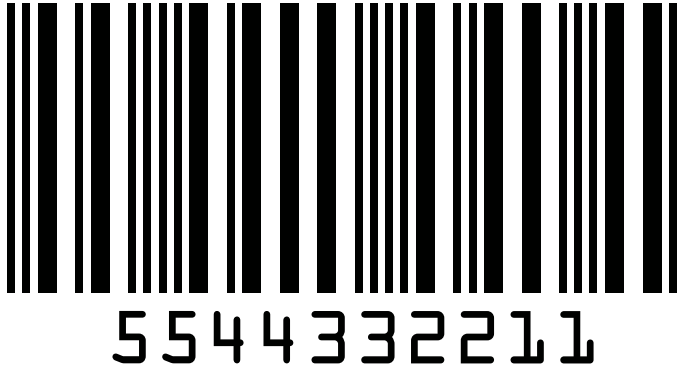

**EAN 13**

SC 9



Figure 11.4: Barcode sample labels (module 1.0) - continued