

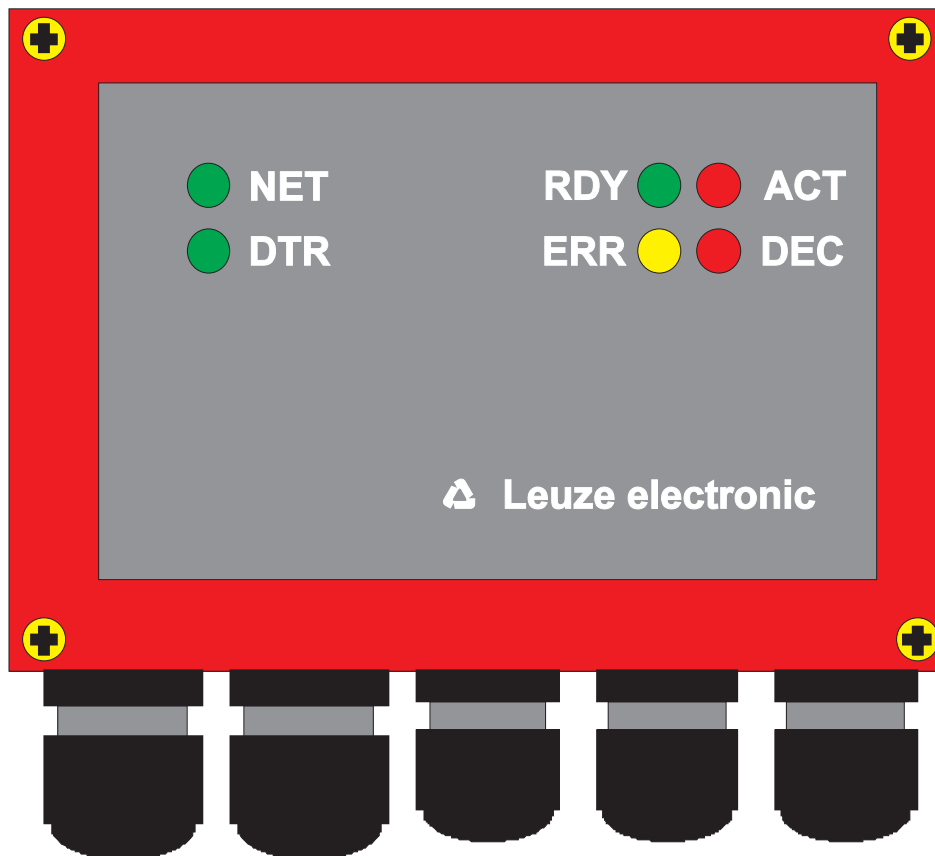

Modular Connector Unit MA 30 / MA 31

Leuze multiNet plus Master

Technical Description



© All rights reserved, especially the rights of production, distribution and translation. Copying or reproductions in any form require the written consent of the manufacturer.
Product names are used without warranty of unrestricted applicability.
Changes due to technical improvement may be made.

1	General Information.....	2
1.1	Explanation of symbols.....	2
1.2	Declaration of Conformity.....	2
2	Device Description.....	3
2.1	Differences between MA 30 / MA 31.....	3
2.2	Function of the MA 30/31.....	3
2.3	Addressing in the network.....	5
2.4	Control elements of the MA 30/31.....	6
2.5	MA 30/31 as network master.....	9
2.6	Service mode.....	10
2.7	Specifications.....	12
2.8	Dimensioned drawings.....	13
3	Connection.....	14
3.1	Connecting the host interface.....	14
3.1.1	RS 485 interface:.....	14
3.1.2	RS 232 interface:.....	15
3.1.3	TTY interface:.....	15
3.1.4	RS 422 interface:.....	16
3.2	Connecting the multiNet plus interface.....	16
3.3	Connecting the switching inputs.....	18
3.4	Connecting the switching outputs.....	19
3.5	Connecting the voltage supply.....	21
4	Commissioning.....	22
4.1	Setting the last slave address.....	22
4.2	Setting the host interface.....	22
4.3	multiNet settings.....	24
4.4	Setting up the slaves in the network.....	25
4.5	Managing the parameter sets in the MA 30/31.....	25
4.6	Executing a RESET.....	27
4.6.1	Software RESET ("warm start").....	27
4.6.2	Hardware RESET ("cold start").....	27
5	Appendix.....	28
5.1	Troubleshooting.....	28
5.2	Overview of Commands and Parameters.....	30
5.2.1	General "Online" Commands.....	31
5.3	ASCII table.....	34

1 General Information

1.1 Explanation of symbols

The symbols used in this operating manual are explained below.



Attention!

Pay attention to passages marked with this symbol. Failure to observe the provided instructions could lead to personal injury or damage to equipment.



Notice!

This symbol indicates text passages containing important information.

1.2 Declaration of Conformity

The connector units MA 30 and MA 31 have been developed and manufactured in accordance with applicable European standards and directives.



Notice!

The corresponding declaration of conformity can be requested from the manufacturer.

The manufacturer of the product, Leuze electronic GmbH & Co KG in D-73277 Owen/Teck, possesses a certified quality assurance system in accordance with ISO 9001.



2 Device Description

2.1 Differences between MA 30 / MA 31

With regard to their function as network masters, both connector units MA 30 and MA 31 (referred to simply as MA 30/31 in the following) are identical.

The connection provided on the MA 30 can be used to connect a scanner of the BCL 40 or BCL 80 family. The MA 31 is not provided with this connection. The overall height of the MA 31 is, thus, lower ("chapter 2.8 "Dimensioned drawings").

2.2 Function of the MA 30/31

General Information The modular connector units MA 30/31 serve as masters in the Leuze multiNet plus network. In addition to its function as a network controller, the MA 30 is also an intelligent connection and switching box for the bar code reader BCL 40/80.

The MA 30/31 can control up to 30 slaves in a network and can output the read data to a common host interface.

When used in combination with a bar code reader BCL 40/ BCL 80 (referred to in the following as BCL xx), the MA 30 is a fully functional reading station, so that 31 stations can be combined into a network.

Leuze multiNet plus

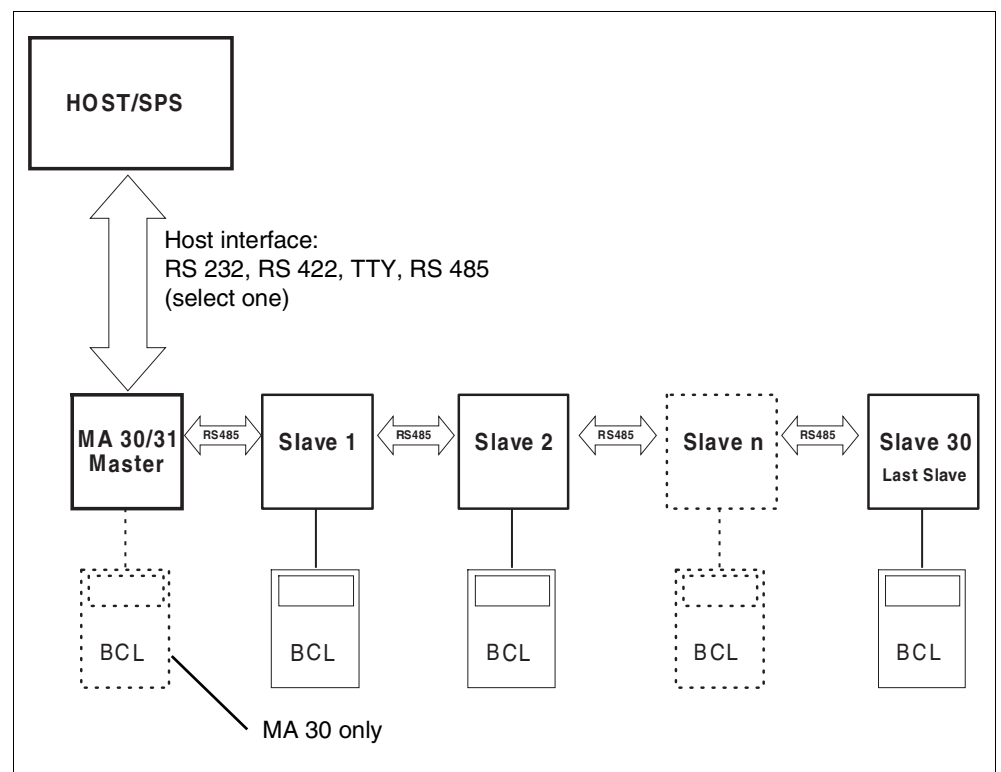

Figure 2.1: MA 30/31 as master in the Leuze multiNet plus

Slaves in the multiNet All Leuze bar code readers and decoders which are capable of multiNet plus can be used as slaves; these are the devices

- BCL 40/BCL 80 with MA 10
- BCL 41 with MA 3-3000
- BCL 21 with MA 2 / MA 2 L / MA 4...
- BCL 31 with MA 2 / MA 2 L / MA 4...
- BCL 90 with MA 90
- MA 21 for hand-read devices and all RS 232-capable devices

Two-wire RS 485 The Leuze MultiNet plus is optimised for fast transmission of scanner data to a primary host computer. Physically, it is composed of a two-wire RS 485 interface which is controlled by a software protocol - the multiNet plus protocol. This makes wiring the network easy and inexpensive since the network wiring is passed through from slave to slave.

Shielded, twisted pair conductors should be used for the multiNet. This allows a total network length of up to 1200m.

Interface modules The connection of the network to the primary computer is via the host interface of the MA 30/31, which can be equipped with four different physical interface modules. Modules are available for RS 232, RS 422, TTY and RS 485.

Protocols Moreover, various data and frame formats can be selected via the software setup (see chapter 4.2 "Setting the host interface"). All standard protocols including **3964/RK512** are, thus, covered.

The big advantage of network operation is the "collection" of data at a single interface to the host computer. This minimises the wiring of the bar code readers and eliminates the need for communication processors/interface units.

2.3 Addressing in the network

Addressing via ASCII address

Addressing the individual bar code readers is necessary for the function of the network so that the read data can be matched to a station.

Leuze uses **2-byte ASCII addressing** in multiNet plus. This addressing is included in each data telegram. This address must be selected at the stations either via hardware (rotary switch) or via software.

The following rules apply:

Master (MA 30/31):	Addr. 00
Slaves:	Addr. 01 to Addr. 30 (sequentially numbered)

No address may occur twice in the network. The numbering must be without gaps, i.e. all addresses up to the *last slave address* (=last subscriber in the network) must be occupied. Be careful to observe the correct selection of network addresses during commissioning.



Notice!

The logical order of the assigned addresses does not have to correspond to the physical order of the read stations in multiNet plus.

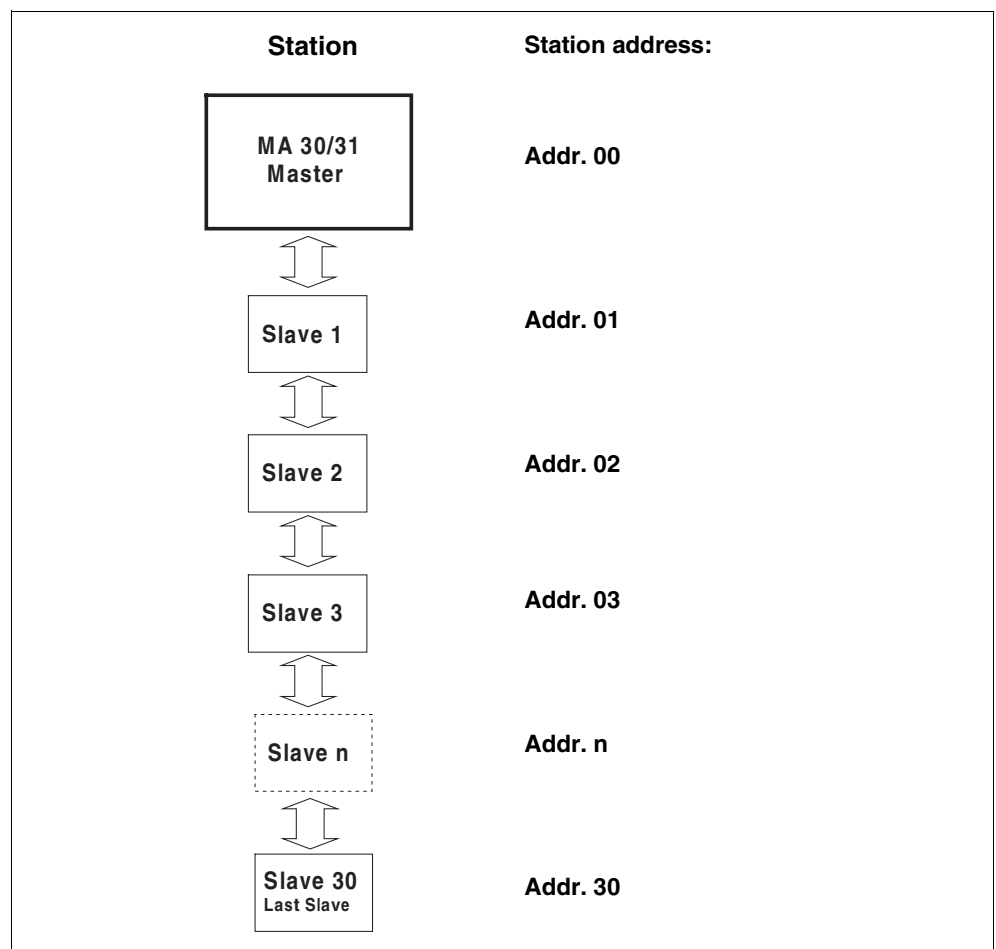

Figure 2.2: Assignment of the network addresses

2.4 Control elements of the MA 30/31

MA 30/31 control elements

Following is a description of the control elements of the MA 30/31. The figure shows the MA 30/31 with opened housing cover.

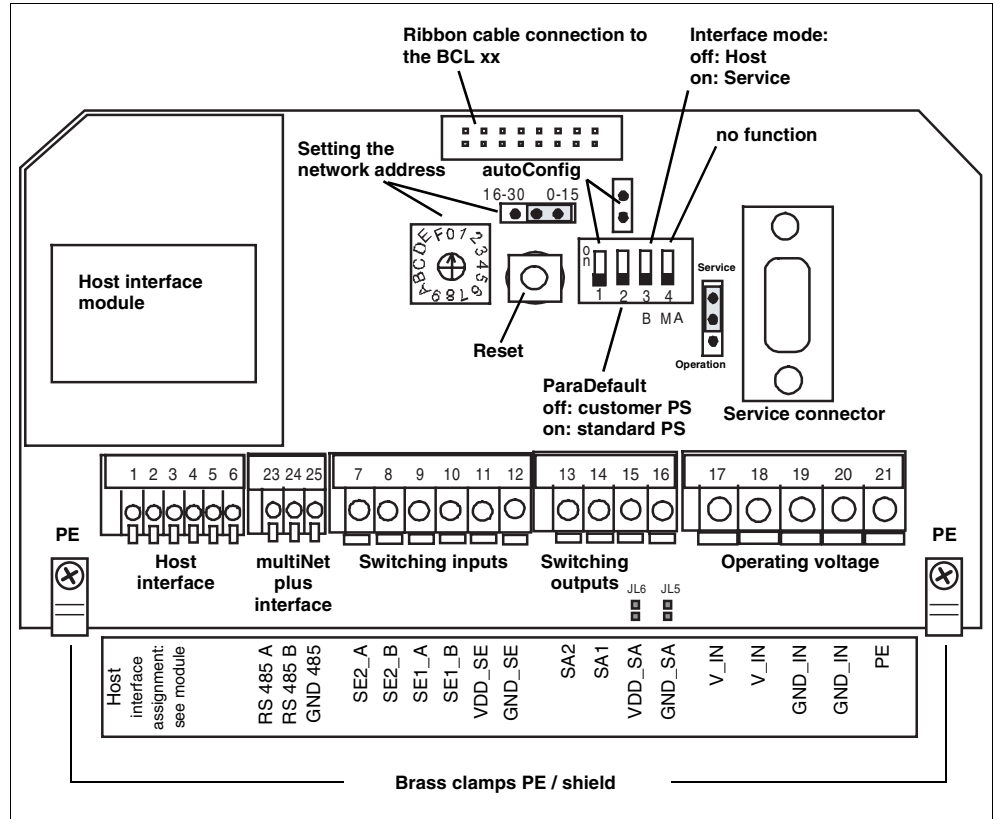

Figure 2.3: Front view: control elements of the MA 30/31

Element	Function
Host interface module	Pluggable interface card for host communication, choice of RS 232, RS 422, TTY, RS 485
Setting the network address	Selection of the address of the highest slave (<i>last slave address</i>)
Rotary switch:	0 through F (16 positions) selectable
Jumper:	right: low address range 0 ... 15 left: high address range 16 ... 30
Ribbon cable connection to BCL xx (MA 30 only)	Connects the SUB-D plug on the bottom of the MA 30 to the electronics in the housing cover
RESET button	press > 0.2s and < 4s: warm start press > 4s: cold start
Jumper autoConfig	open: autoConfig deactivated bridged and <i>DIP switch 1</i> on: autoConfig activated
DIP switch 1 autoConfig	off: autoConfig deactivated on and autoConfig jumper bridged: autoConfig activated
DIP switch 2 ParaDefault	off: with cold start, customer parameter set loaded on: with cold start, standard parameter set loaded
DIP switch 3 interface mode	off: host-interface active/service interface ready to listen on: service interface active/ host-interface deactivated
DIP switch 4 source	no function
Jumper service/operation	up: service/listen (standard setting) down: diagnostic operation (test purposes only)
Service connector	SUB-D 9 pin, RS 232 interface for service/setup operation
Host interface	terminals 1 ... 6: connection terminals for the host computer, PIN assignments dependent on interface module
multiNet plus interface	terminals 23 ... 25: connection terminals for the multiNet plus RS 485
Switching inputs	terminals 7 ... 12: connection terminals for switching inputs 12 ... 36V (polarity arbitrary) choice of potential-free/non-potential-free operation
Switching outputs	terminals 13 ... 16: connection terminals for switching output (second switching output available as an option) choice of potential-free/non-potential-free operation
Solder bridges JL5, JL6	solder bridges for supplying the switching output from the operating voltage or by means of external voltage closed: operating voltage open: external voltage
Operating voltage	terminals 17 ... 21: connection terminals for operating voltage (18 ... 36VDC); with MA 30, also for connected BCL xx

Table 2.1: Explanation: operating elements of the MA 30/31

Indicator LEDs On the rear are 6 LEDs which indicate the operating states of the MA 30/31:

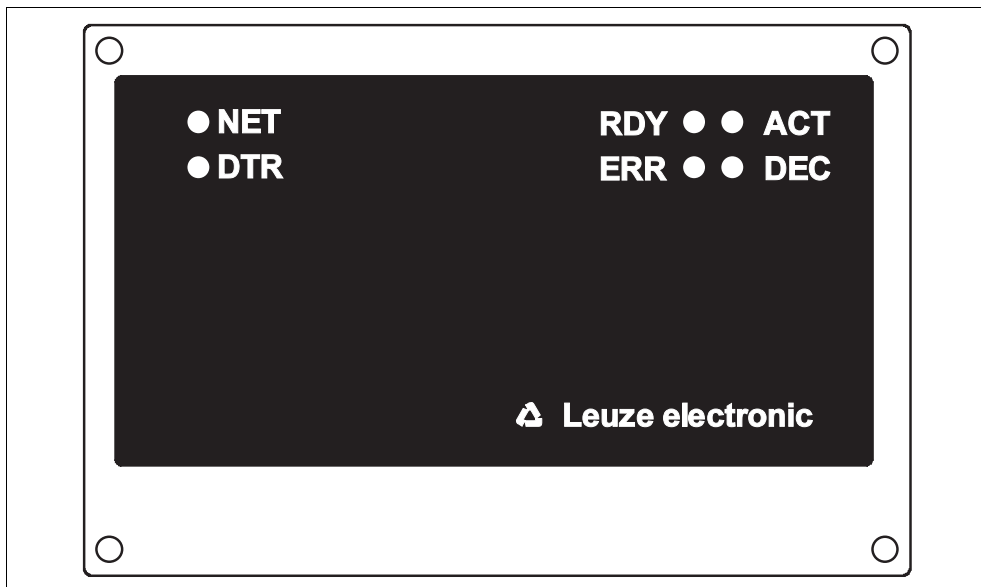

Figure 2.4: Rear view: LEDs on the MA 30/31

LED	Status	Explanation
RDY (green)	Ready	Flashing: Initialisation of a connected scanner Continuous light: Device ready
ERR (yellow)	Error	Flashing: Special function of a connected scanner is being executed Continuous light: Hardware error or serious software error
ACT (red)	Scanner active, autoControl warning	Flashing: autoControl warning output when scanner connected Continuous light: Scanner activated
DEC (green)	Decoding successful	Illuminates for 0.5s upon successful decoding when scanner connected
NET (green)	Network initialisation successful	Indicates whether the network was correctly initialised. It is set after application of the operating voltage as soon as all slaves have reported to the master. If this LED does not illuminate after several seconds, an error is present in the multiNet plus.
DTR (green)	Data transmission	Indicates data transmission to the host interface of the MA 30/31

Table 2.2: Status conditions of the LEDs

A detailed description of the LEDs **RDY**, **ERR**, **ACT** and **DEC** in association with a connected BCL xx can be found in the manual BCL 40/80; these are identical with the LEDs on the MA 10.

2.5 MA 30/31 as network master

Master operation The MA 30/31 is designed specially for master operation within a network. It manages slave data in the multiNet plus and establishes the connection to the primary host computer. Only a few parameters need to be set for master operation (see chapter 4 "Commissioning"). Network commissioning can thus be performed in very little time.

Last slave address The switch for network address setting has an important function. Unlike the slaves, the MA 30/31 address switch is **not** used to set the network address (the master always has the address **Addr.00**), but rather the **last slave address**, i.e. the number of the highest-value slave.

Thus, the MA 30/31 can be "informed" how many slaves are operating on the network without having to call up the software setup. If the network is expanded at a later time, only the address switch needs to be appropriately adjusted.

Time out During the initialisation phase, i.e. after switching on the operating voltage, the master looks for the number of selected slaves. If a slave is not found or does not respond, the master generates a "time out" at this address (response-time time out). At the host interface, the slave address and a "T" are output. For example, "08T" means that no slave has responded at network address 08.

The network remains operational after one or more time outs, but a slave for which a time out has been reported cannot be accessed.

Where to mount the MA 30/31 When mounting the MA 30/31, make sure that it is in an easily accessible, clearly visible location in your system. Once the network has been put into operation, it is possible to set (parameterise) each scanner in the network centrally via the service or primary interface of the MA 30/31 without having to connect a PC/terminal to the individual read stations.

2.6 Service mode

Service interface The MA 30/31 is provided with the service interface for commissioning the reading stations in the network. This interface can be accessed by removing the housing cover on the MA 30/31. It has a 9-pin SUB-D connector.

Connection Thus, you can connect a PC or terminal to the MA 30/31 via the serial interface RS 232/V.24 and parameterise the network. The connection is made using a crossed RS 232 connection cable that establishes the RxD, TxD and GND connections. A hardware handshake via RTS. CTS is not supported at the service interface.

RS 232 connection cable

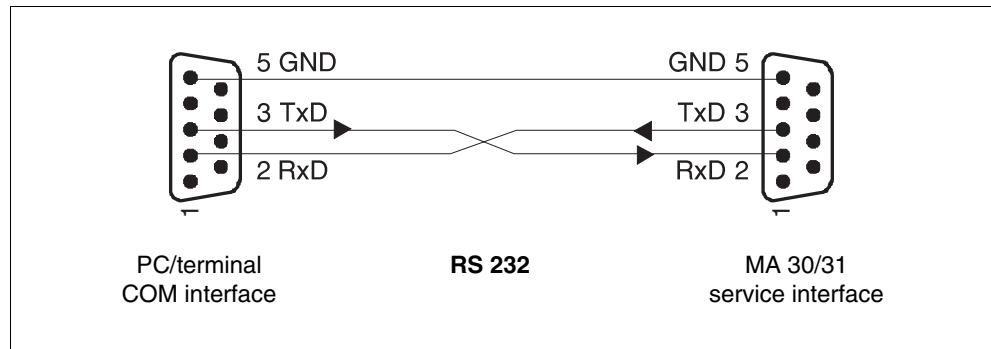

Figure 2.5: Connecting the service interface to a PC/terminal

Service DIP switch In order to activate the service mode, *DIP switch 3* must be set to the "ON" position. The switch must always be in this position when commands are to be sent from a PC to the MA 30/31 via the service interface. If the switch is set to "OFF", data can be listened to passively but cannot be sent to the network.



Attention!

Activating the service mode interrupts the connection to the host computer, i.e. the serial communication with the network takes place exclusively through the service interface.



Notice!

The network can also be parameterised via the host interface. For commissioning, however, parameterisation via a PC is considerably more convenient, especially when the configuration software CONFIG 3.0 from Leuze electronic is used.

CONFIG 3.0 software

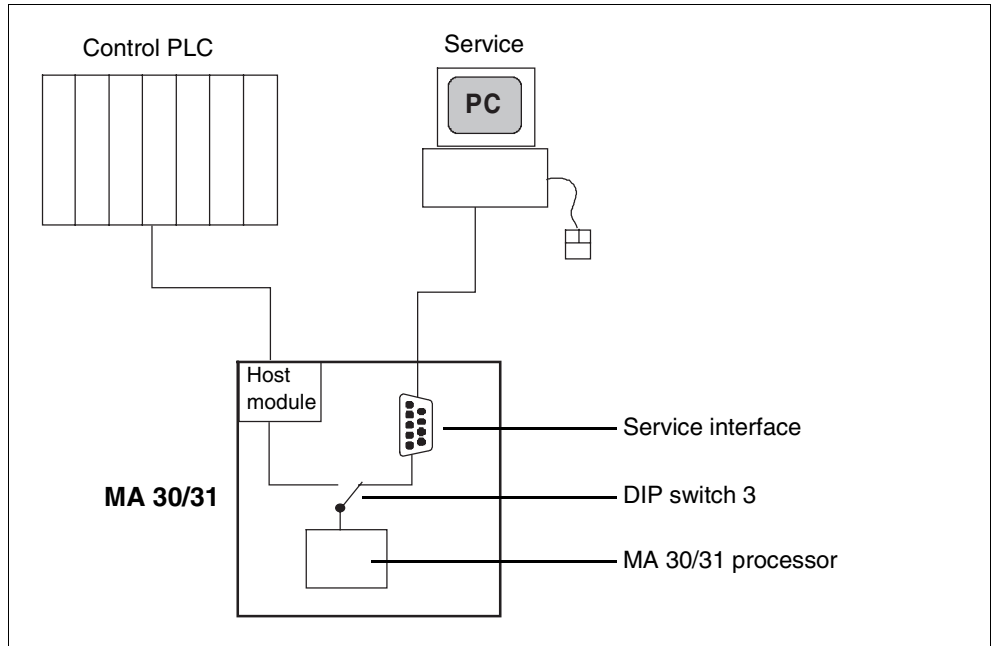

Figure 2.6: Switching between host and service

Data format of the service interface

When *DIP switch 3* is set to "Service", the service interface always functions with the fixed data format:

- **9600 baud**
- **8 data bits**
- **1 stop bit**
- **address 00**
- **no parity**
- **no handshake**

This setting is selected automatically when a MA 30/31 is setup in the CONFIG 3.0 configuration software.

ASCII address

The data frame of the service interface is constructed as shown in the following table.



Attention!

For communicating in the network, make certain that you always select the correct address.

	Prefix 1	Addr. HI	Addr. LO	Data	Terminator 1	Terminator 2
ASCII	STX	0	1	CODE	CR	LF
HEX	02h	30h	31h	43h 4Fh 44h 45h	0Dh	0Ah

Table 2.3: Data frame



Notice!

The data content "CODE" is only an example; here are the actual user data of the frame. Addr. 01 corresponds to slave 1 in the network.

Exiting service mode As soon as *DIP switch 3* is switched back to "Host", the host interface is reactivated.

Data monitoring When the service interface is in this position, it is possible to "listen" to the data via the RS 232 as they are transferred from the MA 30/31 to the host computer (data monitoring). To do this, you must set your PC to the host protocol as the host interface is only passively decoupled with no change of protocol.

2.7 Specifications

General Specifications

Housing	diecast aluminium
Dimensions (WxHxD)	MA 30: 130 x 90 x 93mm MA 31: 130 x 90 x 55mm
Weight	MA 30: approx. 750g MA 31: approx. 650g
Protection class	IP 65

Interfaces

Type (optional)	RS 232, with galvanic isolation RS 422, with galvanic isolation RS 485, with galvanic isolation TTY, with galvanic isolation
Service interface	RS 232 internal, 9-pin Sub D plug, male

Power supply

Operating voltage	18 ... 36VDC
Power consumption	without BCL 40/80: 4VA max. with BCL 40: 9VA max. with BCL 80: 10VA max.

Inputs/outputs

2 switching inputs	galvanically isolated, with supply voltage terminal for sensors 12 ... 36VDC/AC, insulation voltage 500V
2 switching outputs	can be operated galvanically isolated or not isolated, switching voltage 5 ... 48VDC, max. load 500mA

Environmental conditions

Ambient temp. (operation/storage)	0°C ... +50°C / -20°C ... +60°C
Air humidity	max. 90% rel. humidity, non-condensing
Vibration	EN 60068-2-6, Test Fc 0.1 ... 5.0g
Shock	EN 60068-2-27, Test Ea 15g/11ms
Continuous shock	EN 60068-2-29, Test Eb 10g/16ms
EMC	EN 50081-1, EN 50082-2, EN 55022

2.8 Dimensioned drawings

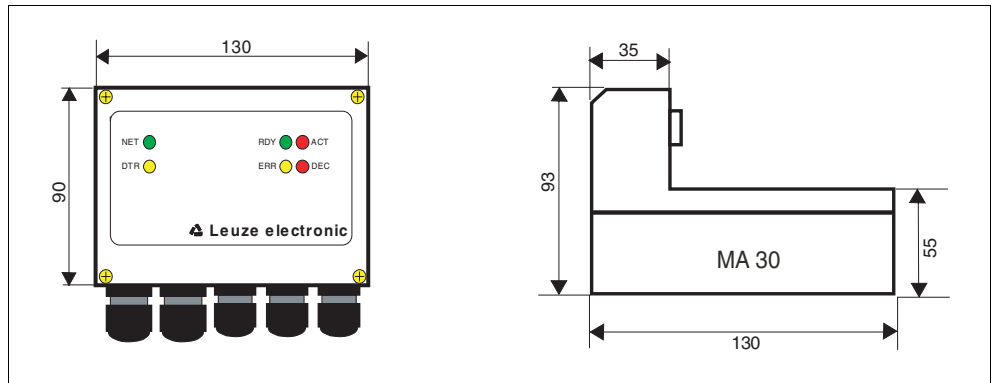

Figure 2.7: Dimensioned drawing MA 30

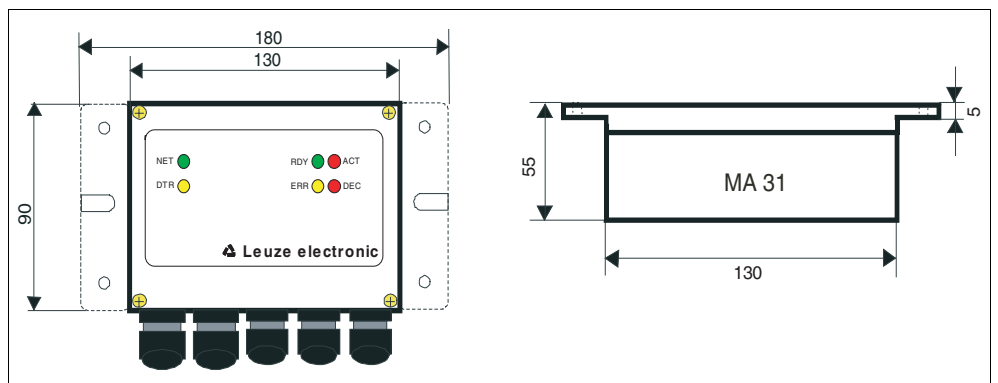

Figure 2.8: Dimensioned drawing MA 31

3 Connection

3.1 Connecting the host interface

Connection terminals: 1 ... 6



Attention!

The **pin assignment** of the connection terminals is dependent on which interface module is plugged in.

Interface module pin assignment

Leuze offers four modules which establish an electrical connection to the serial interfaces RS 232, RS 422, TTY or RS 485. The terminal designations are printed on the module.

The type designation of the MA 30/31 indicates which interface module is installed:

MA 30/31 interface types

Type designation	Interface module of the host interface	Part No.
MA 30 100	RS 485	500 28089
MA 31 100		500 30835
MA 30 110	RS 232	500 28090
MA 31 110		500 30836
MA 30 120	TTY	500 28091
MA 31 120		500 30837
MA 30 130	RS 422	500 28092
MA 31 130		500 30838

Table 3.1: MA 30/31 interface types

3.1.1 RS 485 interface:

RS 485

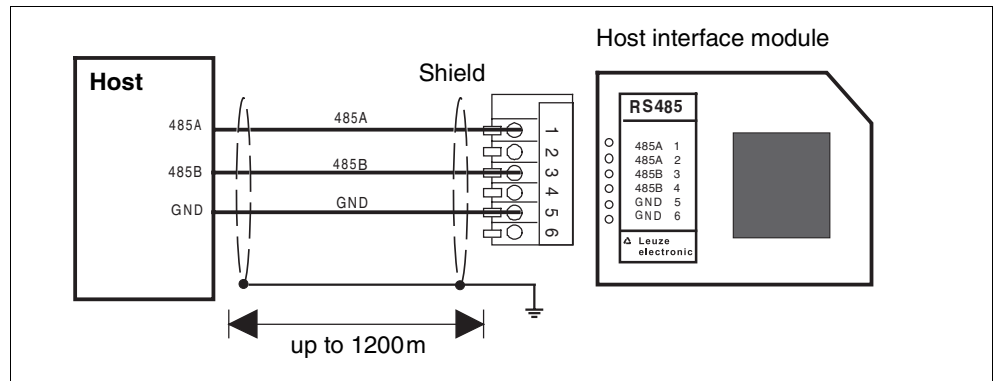

Figure 3.1: Connection of the MA 30/31 to an RS 485 host computer

3.1.2 RS 232 interface:

RS 232

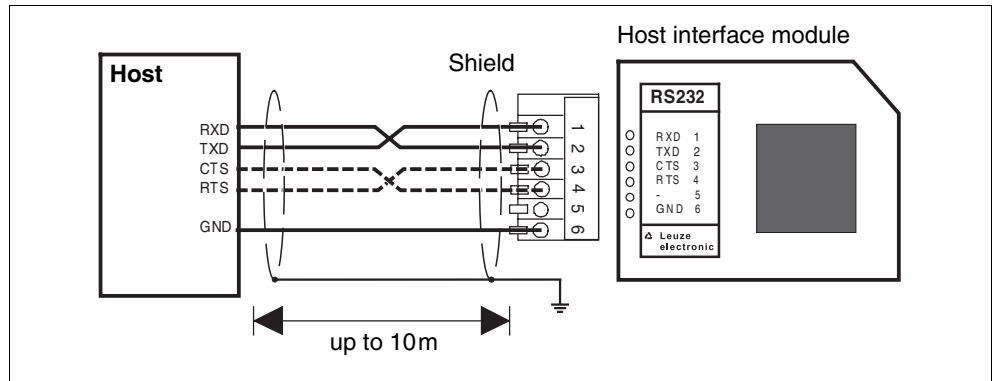

Figure 3.2: Connection of the MA 30/31 to an RS 232 host computer



Notice!

The wiring for RTS and CTS must only be connected if RTS/CTS hardware handshake is used.

3.1.3 TTY interface:

a) MA 30/31 active/host passive:

TTY active

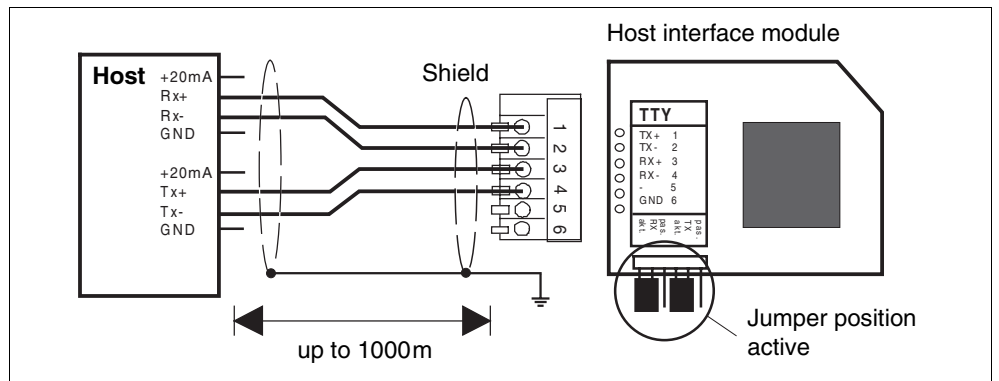

Figure 3.3: Active connection of the MA 30/31 to a TTY host computer

b) MA 30/31 passive/host active:

TTY passive

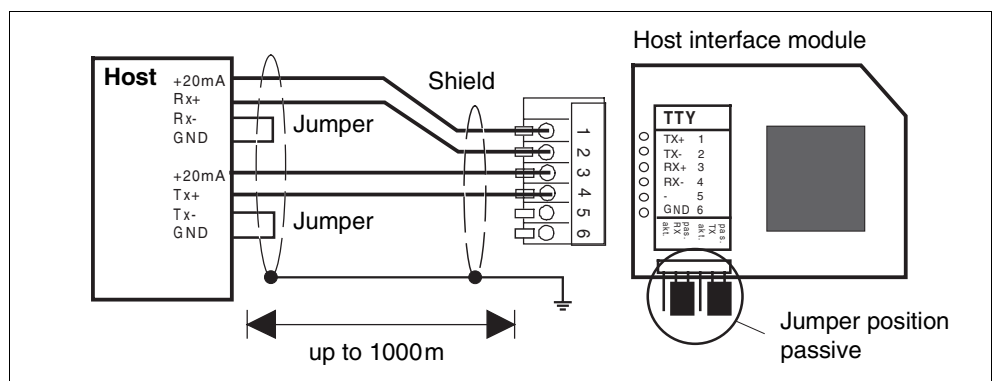

Figure 3.4: Passive connection of the MA 30/31 to a TTY host computer

TTY interface connection hints

Hints for connecting the TTY interface:

- The active subscriber is the one which supplies the current (20mA).
- Switching between active/passive on the host interface card is carried out using two jumper pairs, independent for transmit (Tx) and for receive (Rx).
- The jumpers for active/passive switching must always be changed in pairs (upper and lower jumpers in the same position). Thus, the current source and GND are switched internally at the MA 30/31 host interface module.
- Mixed operation is possible (transmit active/receive passive or vice versa).
- When switching between active and passive operation or vice versa, the pin order of the connection cable is changed.

3.1.4 RS 422 interface:

RS 422

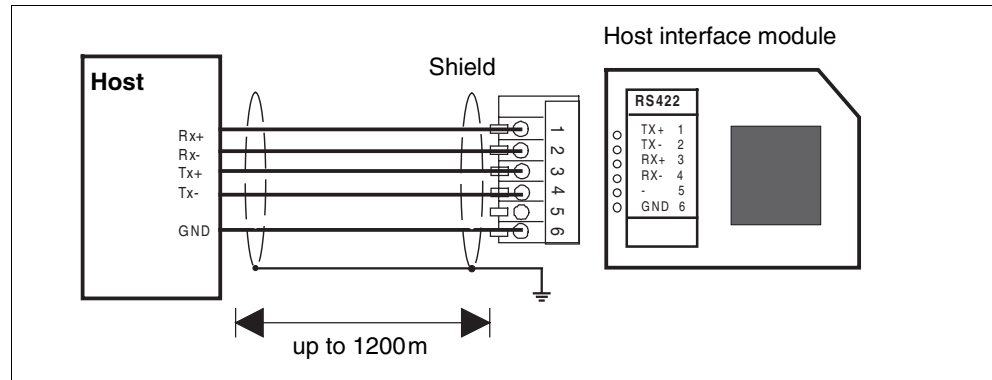

Figure 3.5: Connection of the MA 30/31 to an RS 422 host computer

3.2 Connecting the multiNet plus interface

Connection terminals: 23 ... 25

multiNet plus interface

The multiNet plus interface establishes the connection from the MA 30/31 to the slaves. This is a two-wire RS 485 interface with galvanic decoupling which is passed through from slave to slave.

- Recommended network cable:
- twisted pair
 - cross section: min. 0.2mm²
 - shielded
 - copper resistance <100Ω/km
e.g. LiYCY 2x0.2mm²

The slaves must have an RS 485 multiNet plus interface, i.e. all devices described on page 4 can be connected to the network.

multiNet plus wiring

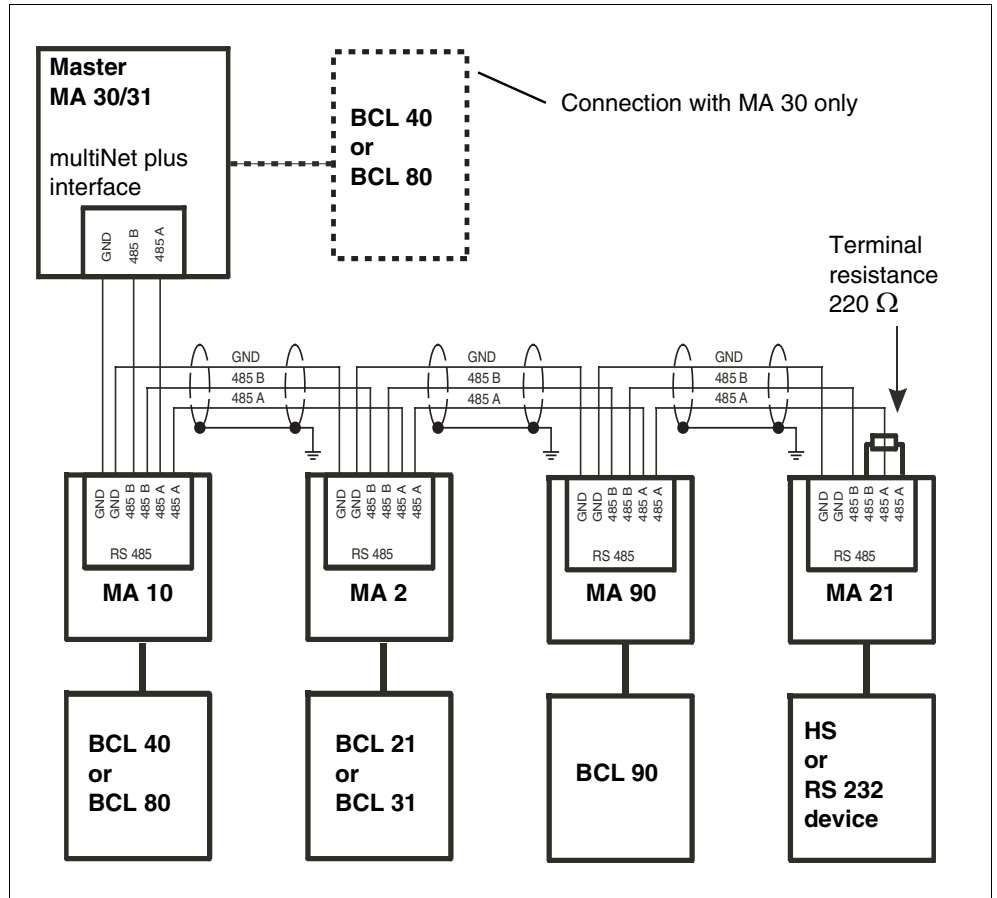

Figure 3.6: multiNet plus wiring

multiNet plus connection hints

Hints for connecting the multiNet plus interface:

- The wires RS 485 A, 485 B and GND are passed through the network. For all connector units (MA xx) the corresponding terminals are provided double.
- Connect the shielding to the slaves with PE.
- The maximum wire length in the network is 1200m.
- The (physically) last slave in the network should be fitted with a terminating resistor of **220Ω** between 485 A and 485 B. This prevents reflections on the multiNet and improves the interference immunity.
- Wires 485 A and 485 B must in no case be exchanged within the network. The multiNet will otherwise not function.

3.3 Connecting the switching inputs

Connection terminals: 7 ... 12

Switching inputs 1 and 2

The MA 30/31 has two galvanically separated switching inputs SE1/SE2.

These are active as soon as a scanner is operated on the **MA 30**.

On the **MA 31** this function is available only via a special software command!

Input voltage: 12 ... 36VDC /AC.

Insulation voltage: 500V

Each switching input is supplied with bidirectional optical couplers and protective resistors.

The switching voltage and GND can be externally applied or taken from the operating voltage VDD_SE and GND_SE.

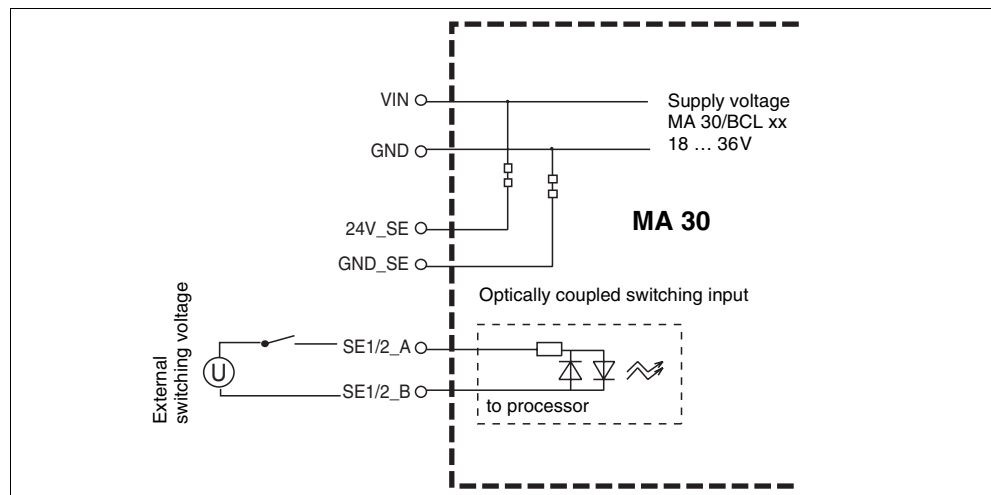

Figure 3.7: Connection of the switching input with an external switching voltage

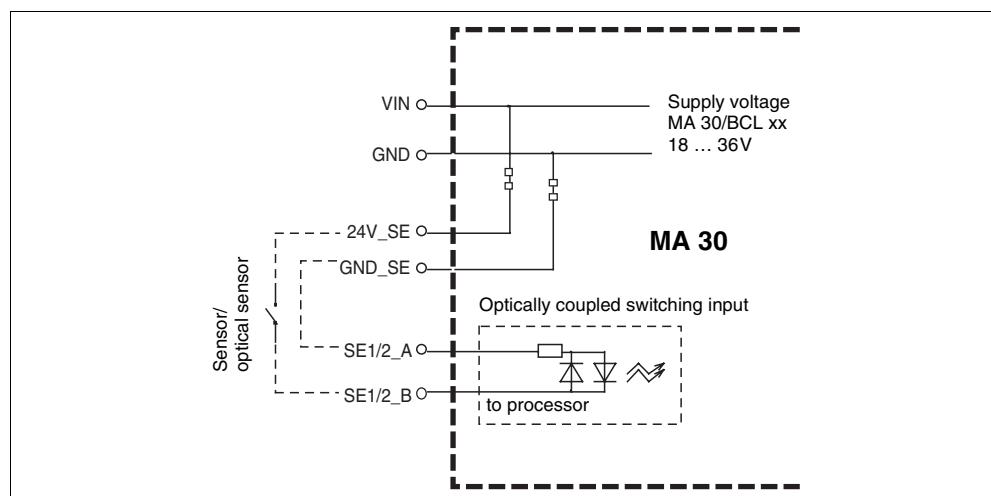

Figure 3.8: Connection of the switching input without an external switching voltage

3.4 Connecting the switching outputs

Connection terminals: 13 ... 16

Switching outputs 1 and 2

The MA 30/31 normally has 2 switching outputs. These are active as soon as a scanner is operated on the **MA 30**. They can be programmed for various switching functions.

On the **MA 31** these switching functions are **not** available!

- Output voltage:** 0 ... 48VDC
- Insulation voltage:** 500V (only in combination with connection type **b**)
- Output current:** $I_{max} = 500\text{mA}$ (with $VDD_SA = 0 \dots 32\text{V}$)
 $I_{max} = 300\text{mA}$ (with $VDD_SA = 32 \dots 48\text{V}$)

The switching voltage can be connected in two different ways:

a) The operating voltage V_IN is used as switching voltage VDD_SA

(factory setting):
 $VDD_SA = V_IN$
 $GND_SA = GND_IN$

b) An external voltage is connected as the switching voltage (galvanically decoupled)

$VDD_SA \neq V_IN$
 $GND_SA \neq GND_IN$



Notice!

The connection between solder bridges JL5 and JL6 must be carefully scratched through so that there is no longer an electrical connection at this point. The switching output is then **galvanically decoupled from the operating voltage**.

The solder bridges are on the MA 30 circuit board directly opposite the connection terminals VDD_SA and GND_SA .

Galvanic decoupling of the switching output

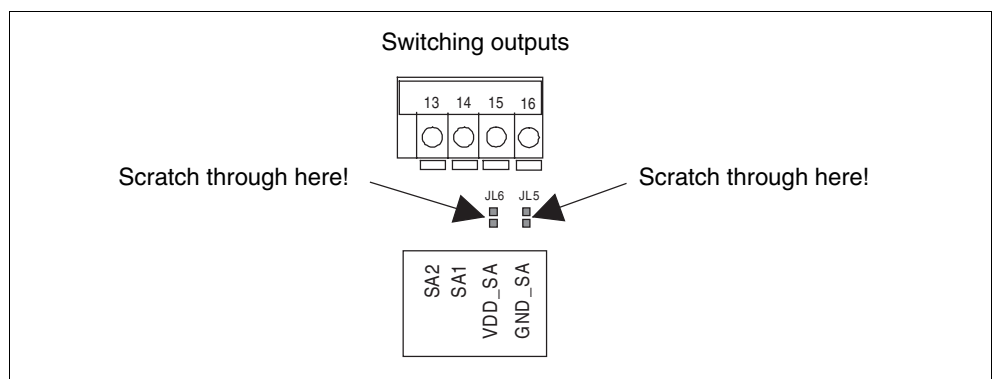

Figure 3.9: Position of the solder bridges JL5 and JL6

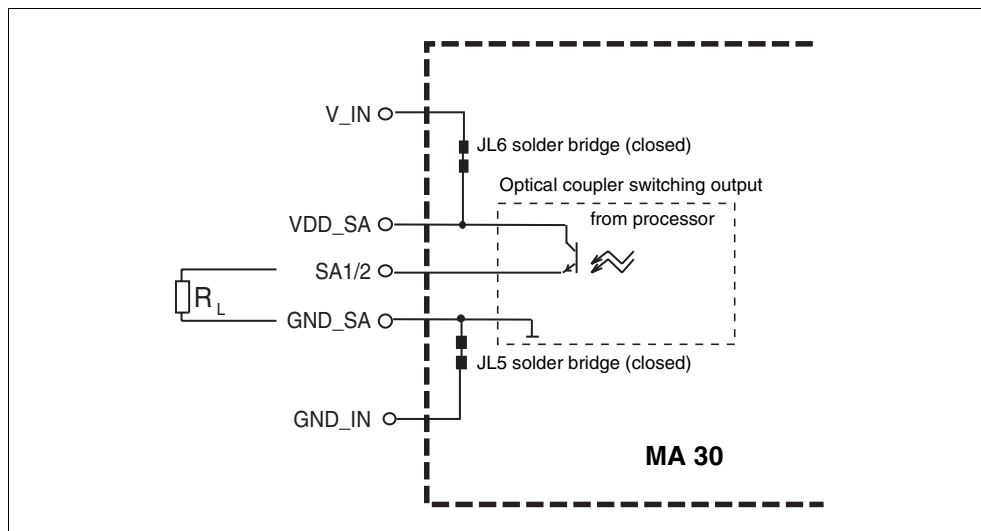

Figure 3.10: Operating voltage is used as switching voltage

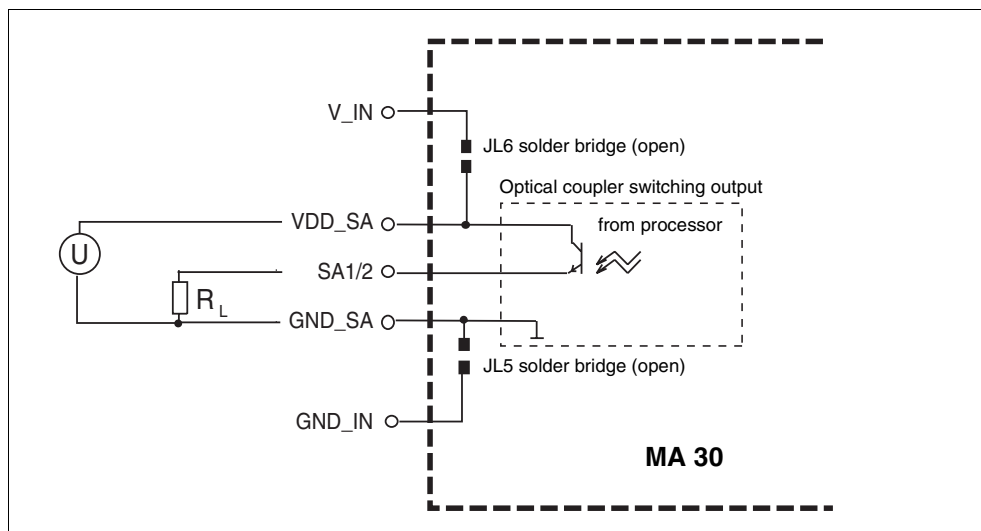

Figure 3.11: Switching voltage connected externally (galvanically decoupled)

Testing the function of the switching output

The function of the switching output can be tested when the cover of the MA 30 is open. There is a red SMD LED directly adjacent to the connection terminal for the switching output which illuminates when there is a HI potential at the switching output (log. 1).

Observe that the event which triggers the setting of the switching output must be set and activated in the software setup of the BCL xx. For further information see the BCL handbook.

3.5 Connecting the voltage supply

Connection terminals: 17 ... 21

Voltage supply Connection terminals for the voltage supply for the MA 30/31 and a BCL 40 or BCL 80 which may be connected to the MA 30.

Input voltage: 18 ... 36VDC

Power consumption: 4VA max. MA 30/31 without BCL 40/80
 9VA max. MA 30 with BCL 40
 10VA max. MA 30 with BCL 80

Terminal 17, 18:	V_IN	(pos. operating voltage)
Terminal 19, 20:	GND_IN	(reference voltage, ground)
Terminal 21:	PE	(protective lead; earth)



Notice!

The terminals for V_IN and GND_IN are double for ease of wiring. Thus, the supply voltage can be passed from one read station to the next.

4 Commissioning

Setting parameters To activate network operation of the MA 30/31, it may be necessary to set several parameters. For best results, use the CONFIG 3.0 configuration software for PCs, a program developed expressly for this purpose. This allows the use of a fixed data format to adjust via the service interface of the MA 30/31 the master and all slaves in the network without interrupting the connection to the host computer.

4.1 Setting the last slave address

Last slave address The MA 30/31 searches for the selected number of slaves in the network when the operating voltage is switched on. The number of the slave with the highest address is called the *last slave address*. This information must be passed on to the MA 30/31. There are two possibilities:

- Setting the *last slave address* with the rotary switch on the MA 30/31
- Setting the *last slave address* via software setup (rotary switch in position "0")

A hardware address has a higher priority than a software address, i.e. the software address is only evaluated when the rotary switch is in position "0".

On the other hand, a software address does not need to be set if a hardware address >0 has been configured.

It is not necessary to call up the setup when adding one or more subscribers to the network; the rotary switch can simply be turned to the appropriate position. The next time the operating voltage is switched on, the new slave(s) will automatically be added to the network.

If you would like to make the setting using the software setup, you must put the MA 30/31 into operation and configure it from a PC.

4.2 Setting the host interface

Host interface Prior to the initial commissioning of the host interface, it must be set to the parameters of the host computer/PLC.

To do this, use the service interface of the MA 30/31 and switch to "service network" (see chapter 2.6 "Service mode").

Using the CONFIG 3.0 configuration software, you can make the changes to the host interface off-line, and then download them to the MA 30/31.

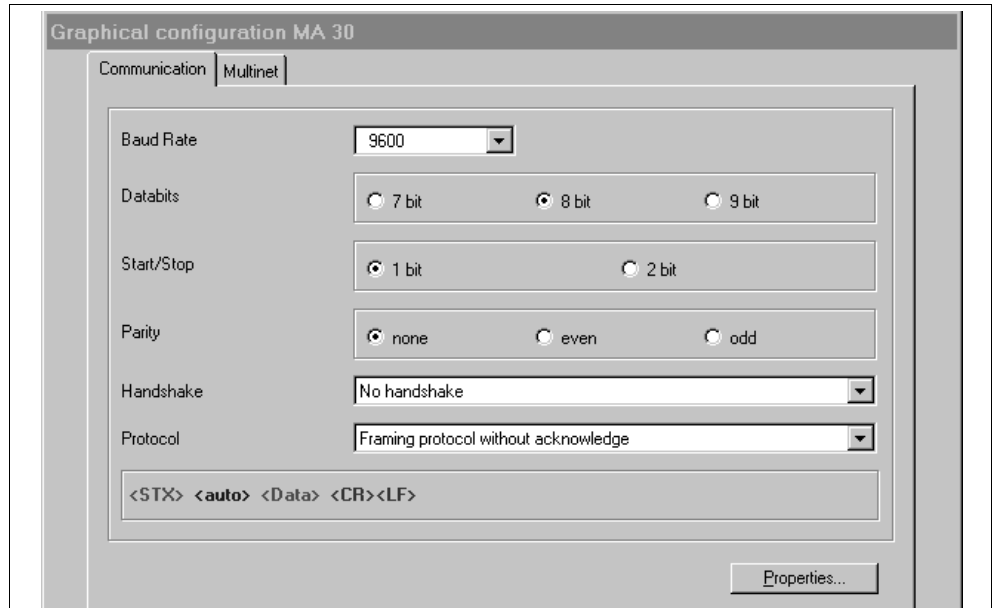

Figure 4.1: Default setting of the host interface menu with the CONFIG 3.0 configuration software

Select the desired baud rate, the stop bits, the data bits and the parity here. You can also set various handshake modes and protocols.

The RK512/3964 protocol can also be selected here. The individual parameters for this protocol can be found in the tree structure configuration under:

Communication -> customer interface -> 3964 / RK 512 protocol

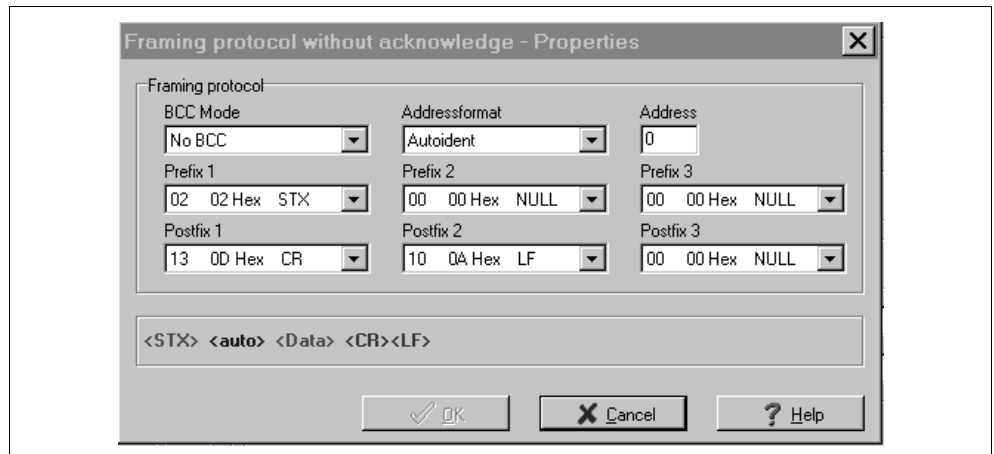

Figure 4.2: Properties menu of the host interface

Here, the frame format (prefix/postfix) as well as the address mode can be adjusted. With the setting "automatic address recognition", the MA 30/31 manages address handling itself. This is the correct setting for nearly all applications.

4.3 multiNet settings

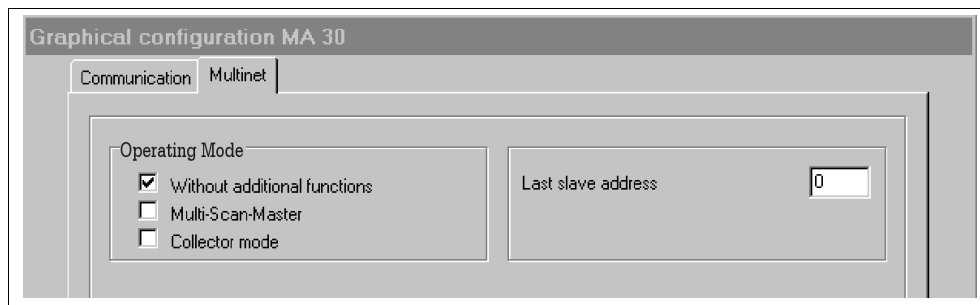

Figure 4.3: multiNet menu default settings

This setting applies for the normal "multiNet" operating mode.

Under "Last slave address", you can set the number of connected slaves. This is analysed only when the rotary switch is in position "0", i.e. the *last slave address* is not set via hardware.

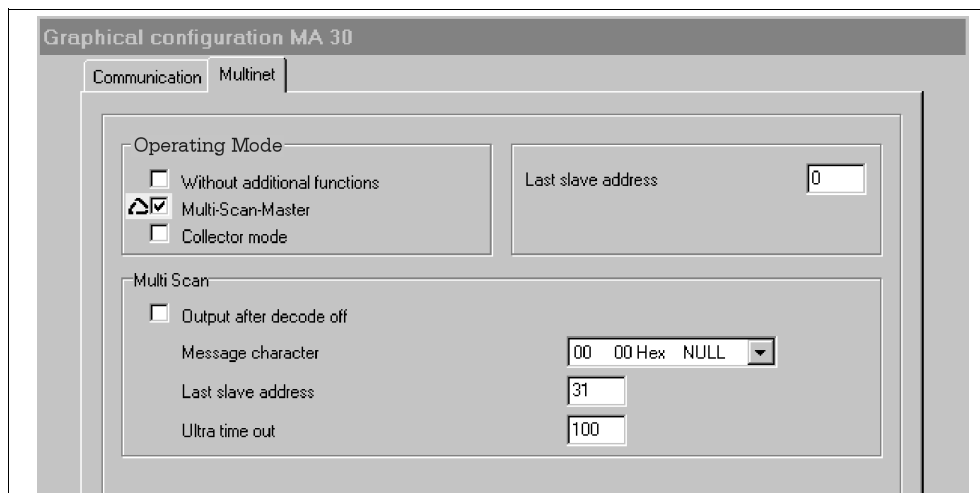

Figure 4.4: Setting the "multiScan" operating mode

The "multiScan" operating mode is required when multiple scanners are to read the same bar code. From the outside, the scanner system appears as a single unit, i.e. the MA 30 sends only one (the first found) read result to the controller.

This application is designed for only **one** label per reading gate.

Triggering is performed either by online command "+" to the Master or by hardware switching input, which can only be connected to the Master.

In the "multiScan" operating mode, the MA 30 functions by default without an address on the host interface. Because of this, this operating mode is active only when the service interface is **not** activated!

Under "Last slave address", you can set the number of connected slaves. This is analysed only when the rotary switch is in position "0", i.e. the "last slave address" is not set via hardware.

4.4 Setting up the slaves in the network

Initialising the network After the parameters of the master setup have been set correctly, the network should be ready for operation, i.e. after switching on the operating voltage all slaves in the network should identify themselves with address and start character "S" to the connected service PC or the host computer (depending on *DIP switch 3*). If, following the initialisation phase (approx. 30 s), neither all slaves are operational or a time out (Addr.+T) has been output, please refer to chapter 5.1 "Troubleshooting".

The connected slaves can now be contacted and parameterised from the master as if they were individual devices.

The only difference is:

Contacting a slave In the network each data telegram must contain an **ASCII address** which specifies for which slave the data are intended.

4.5 Managing the parameter sets in the MA 30/31

Parameter sets This MA 30/31 is capable of managing three types of parameter sets. "Parameter set" (abbr.: PS) refers to a memory area in the EEPROM which contains in numerical format all settings (parameters) of the connector unit MA 30/31 (with MA 30, also for the connected read station e.g. code type, number of characters, output formatting etc.). For the software handling of the parameter sets, these are sequentially numbered from numbers "0" to "2".



Notice!

The BCL xx parameters mentioned in the following are relevant only in combination with the connector unit MA 30.

1. Current parameter set ("0"):

Parameter set which can be modified using online or off-line setup and contains the current settings of the MA 31 or MA 30 and connected BCL xx.

2. Customer-specific parameter set ("1"):

A parameter set stored in the MA 30/31 which can be constructed from a copy of a current, valid parameter set. This is used particularly for saving to memory customer-specific settings independent of the read head (BCL). Thus, when the BCL xx is exchanged, all read station (MA 30 + BCL xx) settings are preserved.

3. Factory default parameter set ("2"):

Leuze standard parameter set which cannot be changed. The settings correspond to the state upon delivery. A hardware RESET (see chapter 4.6.2) resets the MA 30/31 and the BCL xx connected to the MA 30 to the factory settings.

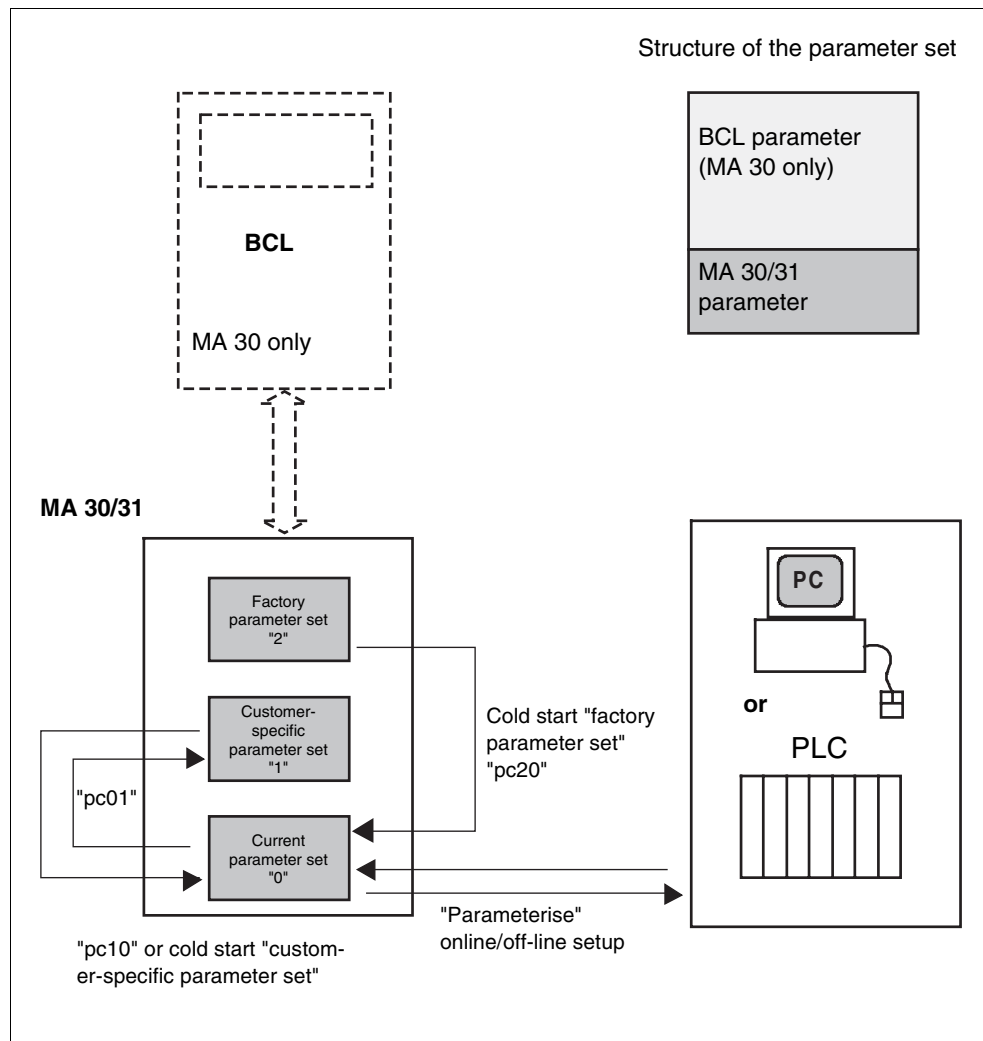

Figure 4.5: Managing parameter sets in the MA 30

The parameter sets are not erased by switching off the operating voltage. The current parameter set is used on start-up. If this is invalid, the customer-specific parameter set is loaded.

"parameter copy" command

With the online command *parameter copy*, abbreviated "**pc**", you can copy a given parameter set as a backup, so to speak, into the customer-specific parameter set and use a hardware RESET to return the read station to this state at any time (see chapter 4.6.2).

Commands for handling the parameter sets via software:

- pc01:** copies the current parameter set to the customer-specific parameter set
- pc10:** copies the customer-specific parameter set to the current parameter set (corresponds to hardware RESET with customer-specific parameters)
- pc20:** copies the Leuze factory parameter set to the current parameter set

4.6 Executing a RESET

4.6.1 Software RESET ("warm start")

Software RESET If the MA 30/31 (or the BCL xx connected to the MA 30) does not respond even though operating voltage is being applied and the RDY LED does not illuminate, you should first carry out a software RESET. Press the "Reset" button on the MA 30/31 for **longer than 0.2 and shorter than 4.0s**. The operating software will be restarted and the devices with the current parameters newly initialised. Following initialisation, the master responds with "00S" and the RDY LED must illuminate.

If the MA 30/31 does not respond even after carrying out a warm start, there may be an error in the setup settings, i.e. the "current parameter set" of the MA 30/31. A hardware RESET (see chapter 4.6.2) returns the parameter set to a defined state so that the units are again operable.

4.6.2 Hardware RESET ("cold start")

Hardware RESET With a cold start, you can either return the MA 30/31 devices (and the BCL xx connected to the MA 30) to the factory settings (factory parameter set) or to your customer-specific parameter set¹. Which parameter set is loaded depends on the position of the *DIP switch 2*. Initiate a cold start by pressing the RESET button for **more than 4s**.



Attention!

A cold start replaces the current parameter set either with your customer-specific parameter set or the Leuze factory parameter set, i.e. any settings made there are lost. Therefore, perform a hardware RESET only when the software cannot be started or when you intentionally want to reset the MA 30/31 (and the BCL xx connected to the MA 30).

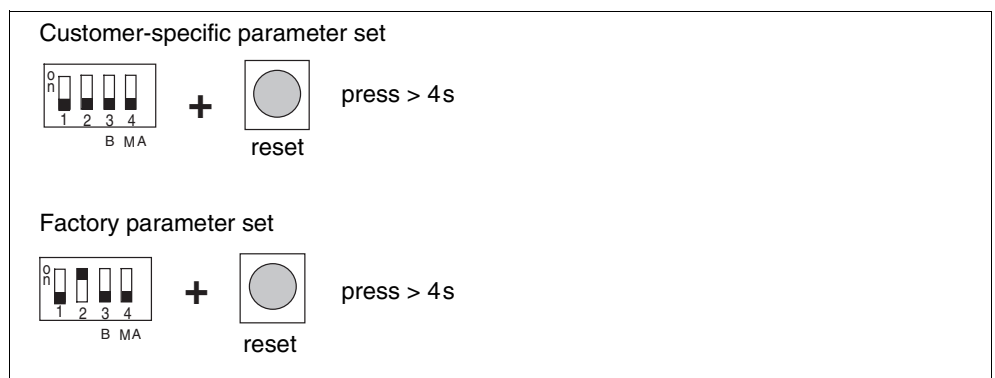

Figure 4.6: Loadable parameter sets during cold start

1. A customer-specific parameter set can be created using the software command "pc01" to store a current, valid parameter set as the customer-specific parameter set in the MA 30/31. Correct storage is acknowledged by "ps0".

5 Appendix

5.1 Troubleshooting

Troubleshooting

If problems should occur during commissioning of the MA 30/31, you can refer to the following table. Typical errors and their possible causes are described here as well as tips for their elimination.

No	Error description	Possible cause(s)	Remedy
Start-up:			
1	No LED illuminates, BCL xx on the MA 30 does not start	Incorrect polarity or improper connection of operating voltage	Check and correct connection
2	LED RDY flashes for longer than 30s after start-up	"Power-On" function test could not be carried out successfully	Test the network wiring; switch the operating voltage on and off
3	Network master (Addr. "00") does not respond to host	No communication between host and master: <ol style="list-style-type: none"> 1. Incorrect interface type plugged in 2. Interface incorrectly connected 3. Incompatible data format between host and MA 30/31 4. <i>DIP switch 3</i> set to "Service" 	<ol style="list-style-type: none"> 1. Replace the interface module 2. Correct according to the connection diagram 3. Check the data format and change in the master setup 4. Set <i>DIP switch 3</i> to "Host"
4	Master responds with "00S", the connected slaves do not respond	<ol style="list-style-type: none"> 1. <i>Last slave address</i> not set on the MA 30/31 2. <i>DIP switch 4</i> set to ON 	<ol style="list-style-type: none"> 1. Set <i>Last Slave Address</i> with control knob or Master setup, after which a new start has to be performed, either by Online command 'H' or by voltage off -> on. 2. Set <i>DIP switch 4</i> to OFF
5	Master responds with "00S", all connected slaves respond with time out (e.g. "01T, 02T, 03T etc.)	<ol style="list-style-type: none"> 1. Interruption or polarity reversal of the multiNet plus interface (RS 485) 2. The slaves have not recognised the "multiNet" protocol type and are operating with a different data format 	<ol style="list-style-type: none"> 1. Test and correct the connection; wires A and B must not be interchanged 2. Test and correct settings for the host protocol of the slaves at the service interface: <p>data format: multiNetMode</p> <p>baud rate: 57600</p> <p>protocol: multiNet plus Slave</p>

No	Error description	Possible cause(s)	Remedy
6	Master and slaves respond with "Addr.+S"; individual slaves respond with time out (e.g. 03T)	<ol style="list-style-type: none"> Slave no. 3 is not properly connected or is using an incorrect data format Slave no. 3 is set to "Service" 	<ol style="list-style-type: none"> Test the connection to slave no. 3 and the host protocol (see above) Switch slave no. 3 to "Operation"
Operation:			
7	LED DTR flashes but no data arrive at the host computer	<ol style="list-style-type: none"> Incorrect protocol set at the host interface of the MA 30/31 <i>DIP switch 3</i> set to "Service" 	<ol style="list-style-type: none"> Set the protocol on the MA 30/31 to the value of the host computer Set <i>DIP switch 3</i> to "Host"
8	LEDs RDY and ERR flash synchronously	The MA 30/31 or the BCL xx connected to the MA 30 are in setup mode; no read tasks can be executed	Exit and, if necessary, save the setup; the MA 30/31 returns to the operating mode
9	LEDs RDY and ERR flash alternatingly; ACT illuminates	The function "autoConfig" on <i>DIP switch 1</i> has been activated for automatic code configuration	After recognising the code to be read, remove the label from the read area and deactivate "autoConfig"
10	LED RDY does not illuminate	Operating software of the MA 30/31 does not function properly	Perform a software RESET

Table 5.1: Error list

5.2 Overview of Commands and Parameters

Online commands can be used to send commands directly to the device for control and configuration.

For this, the MA 30 has to be connected to a host or service computer via the serial interface. The commands described can be sent either via the host or the service interface.

For information on the transmission protocol, please see chapter 2.6 "Service mode".

Syntax "Online" commands consist of one or two ASCII characters followed by command parameters.

No separation characters may be entered between the command and the command parameter(s). Both small and capitalised letters may be used.

Example:

Command '**PC**': Parameter Copy-Function

Parameter '**20**': Copy from parameter memory '2' to parameter memory '0'

This will be sent: '**PC20**'

Notation Commands, command parameters and returned data are enclosed between single quotation marks ' '.

Most "online" commands are acknowledged by the MA 30 and any requested data returned. For commands that are not acknowledged, command execution can be observed or monitored directly on the device.

5.2.1 General "Online" Commands

Software version number

Command	'V'
Description	Requests device version information
Parameter	no
Acknowledgement	<p>'00MA 30 00V 01.15 0027.05.03'</p> <p>The device type is listed in the first line, the device version number in the second line, and the version date in the third line. The prefixed '00' corresponds to the device address. The data which are actually displayed may vary from the values given here.</p>



Notice!

Using this command, you can check whether the connected host or service computer is properly connected and configured. If you do not receive an acknowledgement, please check interface connections, protocol and service switches.

Software reset

Command	'H'
Description	Carries out a software reset. The device is restarted and reinitialised, leaving it in the same state as when the supply voltage is switched on.
Parameter	no
Acknowledgement	'S' (start signal)

Parameter- reset resp. copy Parameter.

Command	'PC'																						
Description	Copies the given source parameter set into the given target parameter set																						
Parameter	<p>'0' current parameter set. '1' customer-specific parameter set. '2' parameter set with factory default settings. Examples: 'PC20': Parameter Reset (to factory settings). 'PC01': The current parameter set is copied in the customer-specific parameter set (backup). 'PC10': Reset to customer-specific settings!</p> <p>Attention! With this command, the parameter sets of any connected bar code reader will be influenced in the same way.</p>																						
Acknowledgement	<p>All possible acknowledgements are listed below.</p> <table border="1"> <thead> <tr> <th>Acknowledgement</th> <th>Description</th> </tr> </thead> <tbody> <tr> <td>'PS0'</td> <td>valid parameter set.</td> </tr> <tr> <td>'PS1'</td> <td>other invalid message.</td> </tr> <tr> <td>'PS2'</td> <td>invalid message length.</td> </tr> <tr> <td>'PS3'</td> <td>invalid type of BCC check sum.</td> </tr> <tr> <td>'PS4'</td> <td>invalid BCC check sum.</td> </tr> <tr> <td>'PS5'</td> <td>invalid data length.</td> </tr> <tr> <td>'PS6'</td> <td>invalid message parameters.</td> </tr> <tr> <td>'PS7'</td> <td>invalid start address in parameter set.</td> </tr> <tr> <td>'PS8'</td> <td>invalid CRC check sum of parameter set.</td> </tr> <tr> <td>'PS9'</td> <td>invalid type of parameter set.</td> </tr> </tbody> </table>	Acknowledgement	Description	'PS0'	valid parameter set.	'PS1'	other invalid message.	'PS2'	invalid message length.	'PS3'	invalid type of BCC check sum.	'PS4'	invalid BCC check sum.	'PS5'	invalid data length.	'PS6'	invalid message parameters.	'PS7'	invalid start address in parameter set.	'PS8'	invalid CRC check sum of parameter set.	'PS9'	invalid type of parameter set.
Acknowledgement	Description																						
'PS0'	valid parameter set.																						
'PS1'	other invalid message.																						
'PS2'	invalid message length.																						
'PS3'	invalid type of BCC check sum.																						
'PS4'	invalid BCC check sum.																						
'PS5'	invalid data length.																						
'PS6'	invalid message parameters.																						
'PS7'	invalid start address in parameter set.																						
'PS8'	invalid CRC check sum of parameter set.																						
'PS9'	invalid type of parameter set.																						

Notice!

A valid parameter set operation must be acknowledged with 'PS0'. Should an error occur, the command should be repeated. Repeated error acknowledgements indicate an error in the parameter set. If in doubt, contact your Leuze sales or service office (see back page for addresses).

Broadcast command

Command	'B'
Description	Should this command be sent to the MA 30, then all attached commands e.g. a 'V', will be sent to all the devices connected to the multiNet. As an acknowledgement, all devices send their version status back to the MA 30 in this case.
Parameter	All commands can be attached that can be understood by the connected devices. Should for example, all scanners in the multiNet be triggered, then this gives the following command: '00B+' Here '00' is the address for the MA 30, 'B' the Broadcast command and the '+' the attached command.
Acknowledgement	Possible acknowledgements correspond to the acknowledgements of the attached commands. The actual Broadcast command is not acknowledged.



Attention!

This command is very powerful and must be used with caution as incorrect commands can negatively influence the entire network.

5.3 ASCII table

ASCII table

HEX	DEC	CTRL	ABB	DESIGNATION	MEANING
00	0	^@	NUL	NULL	Null
01	1	^A	SOH	START OF HEADING	Start of heading
02	2	^B	STX	START OF TEXT	First character of text
03	3	^C	ETX	END OF TEXT	Last character of text
04	4	^D	EOT	END OF TRANSMISSION	End of transmission
05	5	^E	ENQ	ENQUIRY	Request to transmit data
06	6	^F	ACK	ACKNOWLEDGE	Positive response
07	7	^G	BEL	BELL	Bell symbol
08	8	^H	BS	BACKSPACE	Backspace
09	9	^I	HT	HORIZONTAL TABULATOR	Horizontal tabulator
0A	10	^J	LF	LINE FEED	Line feed
0B	11	^K	VT	VERTICAL TABULATOR	Vertical tabulator
0C	12	^L	FF	FORM FEED	Form feed
0D	13	^M	CR	CARRIAGE RETURN	Carriage return
0E	14	^N	SO	SHIFT OUT	Shift out
0F	15	^O	SI	SHIFT IN	Shift in
10	16	^P	DLE	DATA LINK ESCAPE	Data link escape
11	17	^Q	DC1	DEVICE CONTROL 1 (X-ON)	Device control 1
12	18	^R	DC2	DEVICE CONTROL 2 (TAPE)	Device control 2
13	19	^S	DC3	DEVICE CONTROL 3 (X-OFF)	Device control 3
14	20	^T	DC4	DEVICE CONTROL 4	Device control 4
15	21	^U	NAK	NEGATIVE (/Tape) ACKNOWLEDGE	Negative acknowledge
16	22	^V	SYN	SYNCHRONOUS IDLE	Synchronization
17	23	^W	ETB	END OF TRANSMISSION BLOCK	End of data transmission bloc
18	24	^X	CAN	CANCEL	Cancel
19	25	^Y	EM	END OF MEDIUM	End of medium
1A	26	^Z	SUB	SUBSTITUTE	Substitution
1B	27	^[ESC	ESCAPE	Escape
1C	28	^\	FS	FILE SEPARATOR	File separator
1D	29	^]	GS	GROUP SEPARATOR	Group separator
1E	30	^^	RS	RECORD SEPARATOR	Record separator
1F	31	^_	US	UNIT SEPARATOR	Unit separator
20	32		SP	SPACE	Space
21	33		!	EXCLAMATION POINT	Exclamation point
22	34		"	QUOTATION MARK	Quotation mark
23	35		#	NUMBER SIGN	Number sign
24	36		\$	DOLLAR SIGN	Dollar sign
25	37		%	PERCENT SIGN	Percent sign
26	38		&	AMPERSAND	Ampersand
27	39		'	APOSTROPHE	Apostrophe
28	40		(OPENING PARENTHESIS	Opening parenthesis
29	41)	CLOSING PARENTHESIS	Closing parenthesis
2A	42		*	ASTERISK	Asterisk
2B	43		+	PLUS	Plus
2C	44		,	COMMA	Comma
2D	45		-	HYPHEN (MINUS)	Hyphen (minus)
2E	46		.	PERIOD (DECIMAL)	Period (decimal)
2F	47		/	SLANT	Slant
30	48		0		
31	49		1		
32	50		2		
33	51		3		

HEX	DEC	CTRL	ABB	DESIGNATION	MEANING
34	52		4		
35	53		5		
36	54		6		
37	55		7		
38	56		8		
39	57		9		
3A	58		:	COLON	Colon
3B	59		;	SEMI-COLON	Semi-colon
3C	60		<	LESS THAN	Less than
3D	61		=	EQUALS	Equals
3E	62		>	GREATER THAN	Greater than
3F	63		?	QUESTION MARK	Question mark
40	64		@	COMMERCIAL AT	Commercial AT
41	65		A		
42	66		B		
43	67		C		
44	68		D		
45	69		E		
46	70		F		
47	71		G		
48	72		H		
49	73		I		
4A	74		J		
4B	75		K		
4C	76		L		
4D	77		M		
4E	78		N		
4F	79		O		
50	80		P		
51	81		Q		
52	82		R		
53	83		S		
54	84		T		
55	85		U		
56	86		V		
57	87		W		
58	88		X		
59	89		Y		
5A	90		Z		
5B	91		[OPENING BRACKET	Opening bracket
5C	92		\	REVERSE SLANT	Reverse slant
5D	93]	CLOSING BRACKET	Closing bracket
5E	94		^	CIRCUMFLEX	Circumflex
5F	95		_	UNDERSCORE	Underscore
60	96		`	GRAVE ACCENT	Grave accent
61	97		a		
62	98		b		
63	99		c		
64	100		d		
65	101		e		
66	102		f		
67	103		g		
68	104		h		
69	105		i		
6A	106		j		
6B	107		k		

HEX	DEC	CTRL	ABB	DESIGNATION	MEANING
6C	108		l		
6D	109		m		
6E	110		n		
6F	111		o		
70	112		p		
71	113		q		
72	114		r		
73	115		S		
74	116		t		
75	117		u		
76	118		v		
77	119		w		
78	120		x		
79	121		y		
7A	122		z		
7B	123		{	OPENING BRACE	Opening brace
7C	124			VERTICAL LINE	Vertical line
7D	125		}	CLOSING BRACE	Closing brace
7E	126		~	TILDE	Tilde
7F	127		DEL	DELETE (RUBOUT)	Delete

Figure 5.1: ASCII Table

Vertrieb und Service

A
 Ing. Franz Schmachtl KG
 Tel. Int. + 43 (0) 732/7646-0
 Fax Int. + 43 (0) 732/785036
 E-mail: office@schmachtl.at
 http://www.schmachtl.at

ARG
 Nortécnica S. R. L.
 Tel. Int. + 54 (0) 11/4757-3129
 Fax Int. + 54 (0) 11/4757-1088
 E-mail: info@nortecnica.com.ar

AUS + NZ
 Balluff-Leuze Pty. Ltd.
 Tel. Int. + 61 (0) 3/97642366
 Fax Int. + 61 (0) 3/97533262
 E-mail: balluff_leuze@balluff.com.au
 http://www.balluff.com.au

B
 Leuze electronic nv/sa
 Tel. Int. + 32 (0) 2/2531600
 Fax Int. + 32 (0) 2/2531536
 E-mail: leuze.info@leuze.be
 http://www.leuze.de

BR
 Leuze electronic Ltda.
 Tel. Int. + 55 (0) 11/4195-6134
 Fax Int. + 55 (0) 11/4195-6177
 E-mail: leuze@electronic@originet.com.br
 http://www.leuze.com.br

CH
 Leuze electronic AG
 Tel. Int. + 41 (0) 1/8340204
 Fax Int. + 41 (0) 1/8332626
 E-mail: info@leuze.ch

CO
 Componentes Electronicas Ltda.
 Tel. Int. + 57 (0) 4/3511049
 Fax Int. + 57 (0) 4/3511019
 E-mail: rigogigu@col3.telecom.com.co

CZ
 Schmachtl CZ Spol. SR. O.
 Tel. Int. + 420 (0) 2/44001500
 Fax Int. + 420 (0) 2/44910700
 E-mail: office@schmachtl.cz
 http://www.schmachtl.cz

DK
 Desim Elektronik APS
 Tel. Int. + 45/70220066
 Fax Int. + 45/70222220
 E-mail: desim@desim.dk
 http://www.desim.dk

D
 Leuze electronic GmbH + Co KG
 Geschäftsstelle Dresden
 Telefon 0351/2841105
 Telefax 0351/2841103
 E-mail: vgd@leuze.de

Lindner electronic GmbH
 Vertrieb Nord, Hannover
 Telefon 0511/966057-0
 Telefax 0511/966057-57
 E-mail: lindner@leuze.de

W + M plantechnik GmbH + Co. KG
 Vertrieb West, Wuppertal
 Telefon 0202/37112-0
 Telefax 0202/318495
 E-mail: info@wm-plantechnik.de

Leuze electronic GmbH + Co KG
 Geschäftsstelle Frankfurt
 Telefon 06181/9177-0
 Telefax 06181/917715
 E-mail: vgf@leuze.de

Leuze electronic GmbH + Co KG
 Geschäftsstelle Owen/Bad.-Württ.
 Telefon 07021/9850-910
 Telefax 07021/9850-911
 E-mail: vgo@leuze.de

Leuze electronic GmbH + Co KG
 Geschäftsstelle München
 Telefon 08141/5350200
 Telefax 08141/5350220
 E-mail: vgm@leuze.de

E
 Leuze electronic S.A.
 Tel. Int. + 34 93/4097900
 Fax Int. + 34 93/4903515
 E-mail: leuze@leuze.net

ET
 A Plus Systems
 Tel. int. + 20 (0) 2/4189036
 Fax int. + 20 (0) 2/4141280
 E-mail: elfaf@aplusystems.com.eg

F
 Leuze electronic sarl.
 Tel. Int. + 33 (0) 1/60051220
 Fax Int. + 33 (0) 1/60050365
 E-mail: infos@leuze-electronic.fr
 http://www.leuze-electronic.fr

FIN
 SKS-automaatio Oy
 Tel. Int. + 358 (0) 9/852661
 Fax Int. + 358 (0) 9/8526820
 E-mail: automaatio@sksf.fi
 http://www.sks.fi

GB
 Leuze Mayser electronic Ltd.
 Tel. Int. + 44 (0) 1480/408500
 Fax Int. + 44 (0) 1480/403808
 E-mail: mail@leuzemayser.co.uk
 http://www.leuzemayser.co.uk

GR
 UTECO A.B.E.E.
 Tel. Int. + 30 (0) 210/4210050
 Fax Int. + 30 (0) 210/4212033
 E-mail: uteco@uteco.gr
 http://www.uteco.gr

RUS + EST + LV + LT
 All Impex
 Tel. + Fax +7 095/9332097
 E-mail: adz-sensor@narod.ru
 http://www.adz-sensor.narod.ru

H
 Kvalix Automatika Kft.
 Tel. Int. + 36 (0) 1/2722242
 Fax Int. + 36 (0) 1/2722222
 E-mail: info@kvalix.hu
 http://www.kvalix.hu

HK
 Sensortech Company
 Tel. Int. + 852/26510188
 Fax Int. + 852/26510388
 E-mail: sensortech@netvigator.com

I
 IVO Leuze Vogtle Malanca s.r.l.
 Tel. Int. + 39 02/26110643
 Fax Int. + 39 02/26110640
 E-mail: ivoleuze@tin.it
 http://www.ivoleuze.com

IL
 Galoz electronics Ltd.
 Tel. Int. + 972 (0) 3/9023456
 Fax Int. + 972 (0) 3/9021990
 E-mail: hirschfeld@galoz.co.il

IND
 Global Tech (India) Pvt. Ltd.
 Tel. Int. + 91 (0) 20/4470085
 Fax Int. + 91 (0) 20/4470086
 E-mail: global_tech@vsnl.com

J
 C. Illies & Co., Ltd.
 Tel. Int. + 81 (0) 3/34434111
 Fax Int. + 81 (0) 3/34434118
 E-mail: tyo-mp@illies.de
 http://www.illies.de

KOR
 Leuze electronic Co., Ltd.
 Tel. Int. + 82 (0) 31/3828228
 Fax Int. + 82 (0) 31/3828522
 E-mail: hgshim@leuze.co.kr
 http://www.leuze.co.kr

MAL
 Ingermark (M) SDN.BHD
 Tel. Int. + 60 (0) 3/60342788
 Fax Int. + 60 (0) 3/60342188
 E-mail: ingmal@tm.net.my

MEX
 Leuze Lumiflex México, S.A. de C.V.
 Tel. Int. + 52 (0) 81/83718616
 Fax Int. + 52 (0) 81/83718588
 E-mail: info@leuzemexico.com.mx
 http://www.leuze.de

N
 Elteco A/S
 Tel. Int. + 47 (0) 35/573800
 Fax Int. + 47 (0) 35/573849
 E-mail: firmapost@elteco.no
 http://www.elteco.no

NL
 Leuze electronic B.V.
 Tel. Int. + 31 (0) 418/653544
 Fax Int. + 31 (0) 418/653808
 E-mail: info@leuze.nl
 http://www.leuze.nl

P
 LA2P, Lda.
 Tel. Int. + 351 (0) 21/4447070
 Fax Int. + 351 (0) 21/4447075
 E-mail: la2p@ip.pt
 http://www.la2p.pt

PL
 Balluff Sp. z. o. o.
 Tel. Int. + 48 (0) 22/8331564
 Fax Int. + 48 (0) 22/8330969
 E-mail: balluff@balluff.pl
 http://www.balluff.pl

RCH
 Imp. Tec. Vignola S.A.I.C.
 Tel. Int. + 56 (0) 32/256521
 Fax Int. + 56 (0) 32/258571
 E-mail: vignoval@entelchile.net

ROC
 Great Cofue Technology Co., Ltd.
 Tel. Int. + 886 (0) 2/29838077
 Fax Int. + 886 (0) 2/29853373
 E-mail: service@cofue.com.tw
 http://www.cofue.com.tw

RO
 O'Boyle s.v.l.
 Tel. Int. + 40 (0) 56/201346
 Fax Int. + 40 (0) 56/221036
 E-mail: oboyle@rdslink.ro
 http://www.oboyle.ro

RSA
 Countapulse Controls (PTY.) Ltd.
 Tel. Int. + 27 (0) 11/6157556
 Fax Int. + 27 (0) 11/6157513
 E-mail: clive@countapulse.co.za

S
 Leuze SensorGruppen AB
 Tel. + 46 (0) 8/7315190
 Fax + 46 (0) 8/7315105
 E-mail: info@leuze.se
 http://www.leuze.se

SGP + RI + RP
 Balluff Asia Pte. Ltd.
 Tel. Int. + 65/62524384
 Fax Int. + 65/62529060
 E-mail: balluff@balluff.com.sg
 http://www.balluff.com.sg

SK
 Schmachtl SK s.r.o.
 Tel. Int. + 421 (0) 2/54789293
 Fax Int. + 421 (0) 2/54772147
 E-mail: office@schmachtl.sk
 http://www.schmachtl.sk

SLO
 Tipteh d.o.o.
 Tel. Int. + 386 (0) 1/2005150
 Fax Int. + 386 (0) 1/2005151
 E-mail: info@tipteh.si
 http://www.tipteh.si

TH
 Industrial Electrical Co. Ltd.
 Tel. Int. + 66 (0) 2/642-6700
 Fax Int. + 66 (0) 2/642-4249
 E-mail: iecl@ie.co.th
 http://www.ie.co

TR
 MEGA Teknik elek. San. ve Tic. Ltd.
 Tel. Int. + 90 (0) 212/3200411
 Fax Int. + 90 (0) 212/3200416
 E-mail: mega@megateknik.com
 http://www.megateknik.com

USA + CDN
 Leuze Lumiflex Inc.
 Tel. Int. + 1 (0) 973/5860100
 Fax Int. + 1 (0) 973/5861590
 E-mail: info@leuze-lumiflex.com
 http://www.leuze-lumiflex.com

VC
 TR Electronic GmbH
 Shanghai Rep. Office
 Tel. Int. + 86(0)21/58314825
 Fax Int. + 86(0)21/58314829
 E-mail: tr-electronic@online.sh.cn