

**PRK 3B AutoTeach Retro-reflective photoelectric sensors with polarisation filter**

en 06-2011/04 50107259

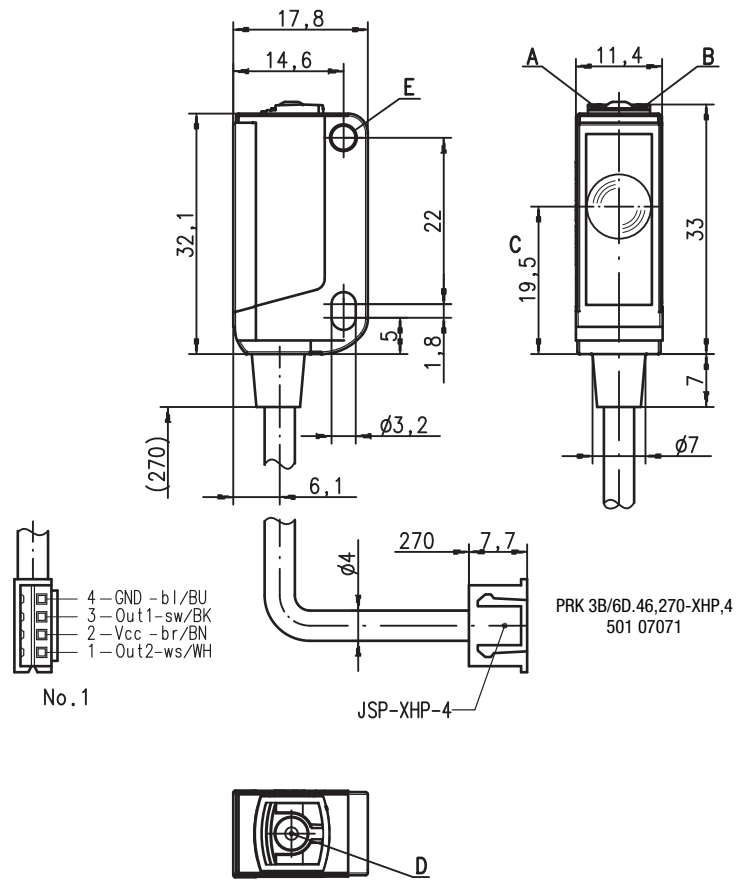

**Dimensioned drawing**



- A Green indicator diode
- B Yellow indicator diode
- C Optical axis
- D Teach button
- E Attachment sleeve

**Electrical connection**

XHP plug connection, 4-pin

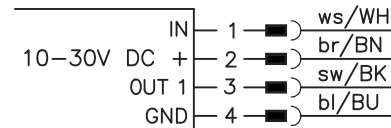

Cable, 4-wire

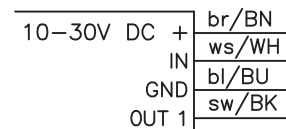

- Polarized retro-reflective photoelectric sensor with visible red light
- Especially for transparent PET and glass bottles
- AutoTeach (cyclic automatic teach event) for contamination compensation
- A<sup>2</sup>LS- Active Ambient Light Suppression
- Push-pull switching output
- High switching frequency for detection of fast events
- Autocollimation principle

**Accessories:**

- (available separately)
- Mounting systems (BT 3...)
  - Reflectors
  - Reflective tapes

We reserve the right to make changes • DS\_PRK3B\_AutoTeach\_en.fm

### Specifications

#### Optical data

Typ. op. range limit (TK(S) 100x100) <sup>1)</sup> 0 ... 5m  
 Operating range <sup>2)</sup> see tables  
 Light source <sup>3)</sup> LED (modulated light)  
 Wavelength 620nm (visible red light, polarized)

#### Timing

Object frequency max. 100Hz with gap duration  $\geq 10$ ms  
 Response time 0.5ms  
 Delay before start-up  $\leq 300$ ms

#### Electrical data

Operating voltage  $U_B$  <sup>4)</sup> 10 ... 30VDC (incl. residual ripple)  
 Residual ripple  $\leq 15\%$  of  $U_B$   
 Open-circuit current  $\leq 18$ mA  
 Switching output/warning output <sup>5)</sup>.../6D.46 1 push-pull output  
 pin 3: PNP dark switching, NPN light switching  
 pin 1: teach input  
 dark switching  
 change signal of 2Hz at the switching output (see remarks)  
 $\geq (U_B - 2V) / \leq 2V$   
 Output current max. 100mA  
 Operating range <sup>6)</sup> automatic setting cyclically performed by AutoTeach every 60s or manual teach-in

Switching function  
 Warning function  
 Signal voltage high/low  
 Output current  
 Operating range <sup>6)</sup>

#### Indicators

Green LED ready  
 Yellow LED light path free  
 Yellow and green LEDs flash error: reflector not present during teach-in or prefailure message for AutoTeach

#### Mechanical data

Housing <sup>7)</sup> plastic (PC-ABS); 1 attachment sleeve, nickel-plated steel  
 Optics cover plastic (PMMA)  
 Weight 20g  
 Connection type 270mm cable with XHP plug connection, 4-pin  
 2m cable (cross section 4x0.20mm<sup>2</sup>)

#### Environmental data

Ambient temp. (operation/storage) -30°C ... +55°C/-30°C ... +70°C  
 Protective circuit <sup>8)</sup> 2, 3  
 VDE safety class III  
 Protection class IP 67  
 Light source free group (in accordance with EN 62471)  
 Standards applied IEC 60947-5-2  
 Certifications UL 508 <sup>4)</sup>

#### Options

**Teach-in input/activation input**  
 Transmitter active/not active  $\geq 8V / \leq 2V$   
 Activation/disable delay  $\leq 1$ ms  
 Input resistance 30k $\Omega$

- 1) Typ. operating range limit: max. attainable range without performance reserve
- 2) Operating range: recommended range with performance reserve
- 3) Average life expectancy 100,000h at an ambient temperature of 25°C
- 4) For UL applications: for use in class 2 circuits according to NEC only
- 5) The push-pull switching outputs must not be connected in parallel
- 6) Life expectancy typically 100,000 storage cycles
- 7) Patent Pending Publ. No. US 7,476,848 B2
- 8) 2=polarity reversal protection, 3=short-circuit protection for all transistor outputs

### Remarks

Adapter plate:

BT 3.2 (part no. 50103844) for alternate mounting on 25.4mm hole spacing (Omron E3Z, Sick W100...)

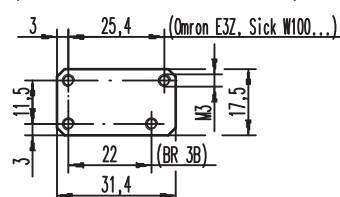

### Tables

Reflectors			Operating range
1	TK(S)	100x100	0 ... 4.0m
2	TK	40x60	0 ... 2.6m
3	TK	20x40	0 ... 1.3m
4	Tape 4	50x50	0 ... 0.7m

1	0		4	5
2	0	2,6	3,2	
3	0	1,3	1,5	
4	0	0,7	1,0	

Operating range [m]  
 Typ. operating range limit [m]

TK ... = adhesive  
 TKS ... = screw type

### Diagrams

### Remarks

- If the receive signal from the reflector is too weak, the sensor indicates the error status by means of fast and simultaneous flashing of the green and yellow LEDs as well as by a change signal of 2Hz at the switching output. Please check the alignment, operating range, and soiling and carry out another teaching.
- Mounting system:



- ① = BT 3 (part no. 50060511)
- ②+③ = BT 3.1 <sup>1)</sup> (part no. 50105585)
- ①+②+③ = BT 3B (part no. 50105546)

1) Packaging unit: PU = 10 pcs.

**PRK 3B AutoTeach Retro-reflective photoelectric sensors with polarisation filter**

**Order guide**

Selection table		Order code →		PRK 3B/6D.46, 270-XHP.4 Part No. 50107071	PRK 3B/6D.46 Part No. 50108026		
<b>Equipment ↓</b>							
Output 1 (OUT 1)	push-pull switching output		PNP, dark switching ●	●	●		
			NPN, light-switching ○	●	●		
Function characteristics	Switching output			●	●		
	warning output (change signal of 2 Hz at the switching output)			●	●		
Input (IN)	teach input			●	●		
Connection	270 mm cable with XHP plug connection, 4-pin			●			
	2.000 mm cable, 4-pin				●		
Configuration	AutoTeach, cyclic every 60s			●	●		
	teach-in via button (lockable) and teach input			●	●		

**General information**

- **Approved purpose:**  
This product may only be used by qualified personnel and must only be used for the approved purpose. This sensor is not a safety sensor and is not to be used for the protection of persons..
- After power-on, an **automatic teach-in** occurs **every 60s (AutoTeach)**.
- The light spot may not exceed the reflector.
- Preferably use MTKS 50x50 reflectors.
- Following an AutoTeach, the device setting is only saved if contamination differences > 8% were detected. Therefore, the typical life expectancy of the device is not affected in practical use.

**AutoTeach (cyclic automatic teach event)**



- **The sensor performs a cyclic AutoTeach every 60s.**  
The sensor waits until the light path is free (e.g. between two bottles). An appropriate safety window is taken into account. Afterwards, an AutoTeach occurs and the sensor compensates for all contamination parameters. The new teach value is only saved if a system contamination > 8% was detected.
- If the receive signal from the reflector is too weak, the sensor indicates the error status by means of fast and simultaneous flashing of the green and yellow LEDs as well as by a change signal of 2Hz at the switching output. Please check the alignment, operating range, and soiling and carry out another teaching.

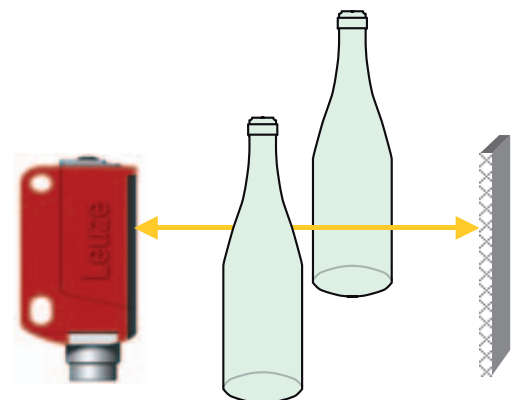

**Teach via teach button for PET and glass bottles**



- **Prior to teaching:**  
**Clear the light path to the reflector!**  
The device setting is stored in a fail-safe way. A reconfiguration following voltage interruption or switch-off is thus not required.



**Teach process (teach button) for PET and glass bottles**

- Press teach button until both LEDs flash **simultaneously**.
- Release teach button.
- Finished - AutoTeach remains active.



If the receive signal from the reflector is too weak, the sensor indicates the error status by means of fast and simultaneous flashing of the green and yellow LEDs as well as by a change signal of 2Hz at the switching output. Please check the alignment, operating range, and soiling and carry out another teaching.

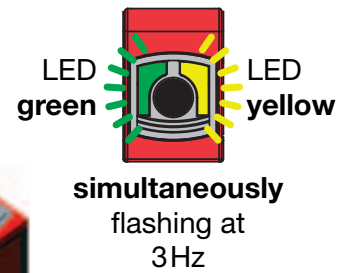
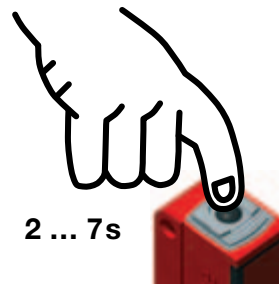

**Locking the teach button via the teach input**



A **static high signal** ( $\geq 4$  ms) at the teach input locks the teach button on the device if required, such that no manual operation is possible (e.g., protection from erroneous operation or manipulation).

If the teach input is not connected or if there is a static low signal, the button is unlocked and can be operated freely.

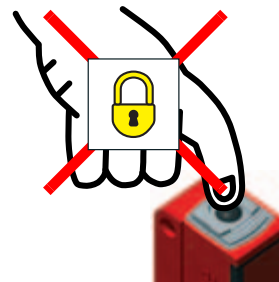

**Teach via teach input for PET and glass bottles**



The following description applies to PNP switching logic!

$$U_{\text{Teach low}} \leq 2V$$

$$U_{\text{Teach high}} \geq (U_B - 2V)$$

**Prior to teaching: Clear the light path to the reflector!**

The device setting is stored in a fail-safe way. A reconfiguration following voltage interruption or switch-off is thus not required.

**Teach process (teach input) for PET and glass bottles**

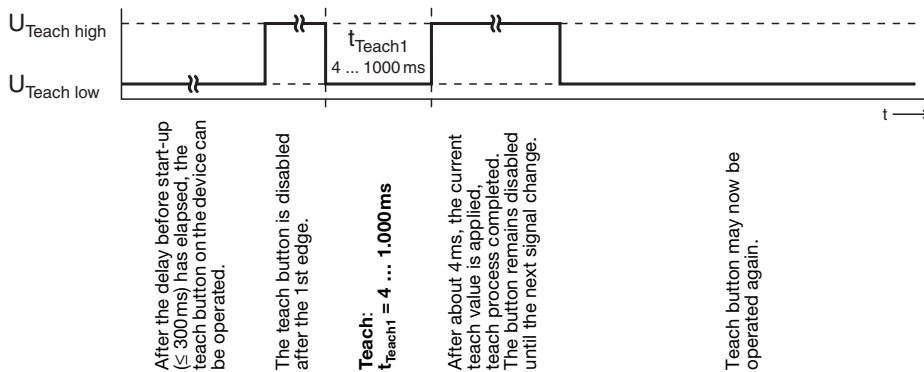

**Quick teach**

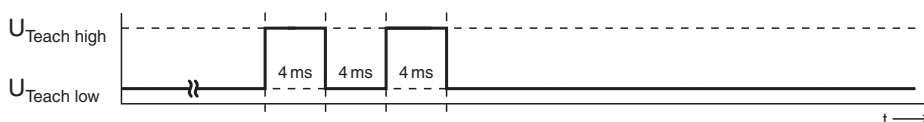

shortest teaching duration for standard teaching: approx. 12ms



If the receive signal from the reflector is too weak, the sensor indicates the error status by means of fast and simultaneous flashing of the green and yellow LEDs as well as by a change signal of 2Hz at the switching output. Please check the alignment, operating range, and soiling and carry out another teaching.