

PRK 92 Ex i Retro-reflective photoelectric sensors with polarisation filter

en 08-2011/01 50111475



0.2 ... 5m



- Compact construction with glass optics and stainless steel housing, protection class IP 67 for industrial application
- Switching output acc. to IEC 60947-5-6 (NAMUR)
- EU type examination certificate DMT 03 ATEX E 029
- Ex II 2G Ex ia IIC T6
- Ex II 2D Ex iaD 21 T80°C

Dimensioned drawing

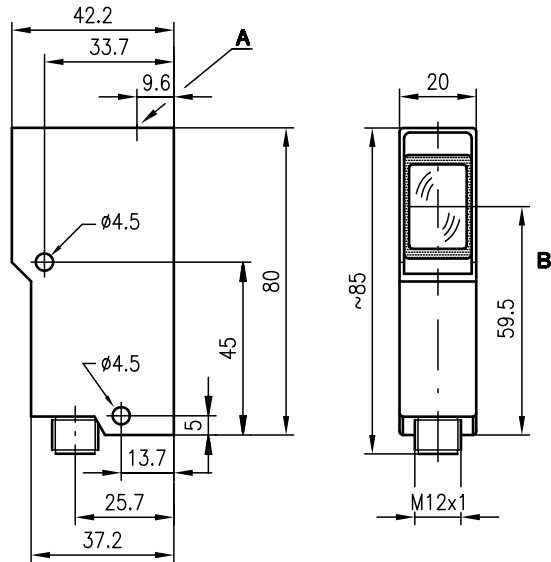

- A** Indicator diode
- B** Optical axis

Electrical connection

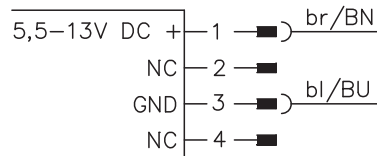

We reserve the right to make changes • DS_PRK92_ex_en.fm



Accessories:

(available separately)

- Mounting systems (BT 92, UMS 1)
- Reflectors
- Reflective tapes
- Blue connection cable for intrinsically safe circuits:
 KB-092-5000-4 ... Ex 50037784
 KB-092-5000-4A ... Ex 50037783
- Isolated switching amplifier (VS 403...)

Specifications

Optical data

Operating range (TK(S) 100x100) ¹⁾	0.2 ... 5m
Light source	LED (modulated light)
Wavelength	660nm (visible red light, polarised)
Intensity	< 1.1 mW/mm ²

Timing

Switching frequency	60Hz
Response time	8.5ms
Delay before start-up	≤ 100ms

Electrical data

Nominal voltage	8.2VDC
Operating voltage U _B	5.5 ... 13VDC (incl. residual ripple)
Residual ripple	max. 0.35V _{SS}
Bias current (light path interrupted)	≤ 1mA
Switching output	NAMUR (IEC 60947-5-6)
Function characteristics	light switching (light/dark setting on switching amplifier)

Indicators

LED yellow	light path free
------------	-----------------



Mechanical data

Housing	diecast zinc
Surface	antistatic epoxy coating (acc. to EN 50014)
Optics	glass
Weight	140g
Connection type	M12 connector

Environmental data

Ambient temp. (operation/storage)	-20°C ... +50°C / -30°C ... +70°C
VDE safety class ²⁾	II
Protective circuit ³⁾	2
Protection class	IP 67
LED class	1 (acc. to EN 60825-1)
Standards applied	IEC 60947-5-2

Explosion protection

Certification	 II 2G Ex ia IIC T6	 II 2D Ex iaD 21 T80°C
Maximum safe voltage	U _{max} 13V	
Maximum safe current	I _{max} 40mA	
Internal capacitance C _i	≤ 70nF	
Internal inductance L _i	≤ 200µH	

- 1) Operating range: recommended range with performance reserve
 2) Rating voltage 250VAC
 3) 2=polarity reversal protection

Tables

Reflectors		Operating range
TK(S)	100x100	0.2 ... 5.0m
TK(S)	50x100	0.2 ... 4.0m
TK(S)	50x50	0.2 ... 3.5m
TK(S)	30x50	0.2 ... 2.0m
TK	82	0.5 ... 3.5m
TK	60	0.2 ... 2.0m
TK	45	0.3 ... 2.5m
Tape 2	100x100	0.4 ... 2.5m

TK ... = adhesive
 TKS ... = screw type
 Tape 2 = adhesive

Diagrams

Order guide

Designation	Part No.
PRK 92/3 L Ex	50080723

Remarks

- **Approved purpose:**
 This product may only be used by qualified personnel and must only be used for the approved purpose. This sensor is not a safety sensor and is not to be used for the protection of persons.
- For operation in potentially explosive atmospheres, an isolated switching amplifier is required.

Operating Instructions for the 92 Ex Series for Use in Potentially Explosive Areas

The sensors produced by Leuze electronic GmbH + Co. KG for use in potentially explosive areas are sensors which function on the optical electronic principle. Without making physical contact, these sensors detect objects which are located in or which pass through the light beam.

The devices of the 92 Ex series (LS throughbeam photoelectric sensor, PRK retro-reflective photoelectric sensor and FRK diffuse reflection light scanner) were designed for use in potentially explosive areas of Zones 1 and 21 (device group II, device category 2) in compliance with standards EN 60079 and EN 61241.

The intrinsic safety of the sensors is ensured only in combination with corresponding electrical equipment according to IEC 60947-5-6 (NAMUR), e.g. isolated switching amplifier VS 403.



Notes!

- An isolated switching amplifier must be used for each sensor. In the case of the throughbeam photoelectric sensor, an isolated switching amplifier is required for both the transmitter and the receiver.
- The sensors must not be connected together at an isolated switching amplifier.
- When using an isolated switching amplifier, it must be ensured that the characteristic data specific to explosion protection of both devices are not exceeded.

Installation, Commissioning



Attention!

- Due to the physical circumstances, the photoelectric sensors of the 92 Ex series must not be used for the protection of persons or for purposes of emergency shutdown.
- The photoelectric sensors of the 92 Ex series must only be installed and maintained by trained electricians.
- The respective applicable national regulations for the installation of electrical equipment in potentially explosive areas must be observed.

During installation and commissioning of the devices, the EC type examination certificate DMT 03 ATEX E 029 is to be observed.

To connect the intrinsically safe sensors with corresponding equipment, it is possible to use, for example, the blue connection cable

KB-092-5000-4 Ex (angular connector, part no. 50037784) or KB-092-5000-4A Ex (axial connector, part no. 50037783) from Leuze electronic GmbH + Co. KG.

Maintenance

No changes may be made to the devices of the 92 Ex series for potentially explosive areas.

Repairs to the sensors may only be performed by persons trained for such work or by the manufacturer.

Defective devices must be replaced immediately.

Cyclical maintenance of the sensors is not necessary.

Depending on the environmental conditions, it may occasionally be necessary to clean the light-emission surfaces of the sensors.

This cleaning must only be performed by persons trained for performing this task.

Chemical Resistance

The 92 Ex series sensors demonstrate good resistance against many diluted acids and bases.

Exposure to organic solvents is possible only under certain circumstances and only for short periods of time.

Resistance to chemicals should be examined on a case by case basis.

EG-Konformitätserklärung

- EC Declaration of Conformity
- Déclaration CE de conformité
- Declaración de conformidad CE

Name des Herstellers:

- Name of the manufacturer:
- Le constructeur:
- Nombre del fabricante:

Leuze electronic GmbH+Co. KG

Anschrift:

- Address:
- domicile:
- Dirección:

In der Braike 1 D-73277 Owen/ Teck

Erklärt unter alleiniger Verantwortung, dass das Produkt mit der Bezeichnung:

- declares under sole responsibility that the products with the designation:
- assurant sa pleine et entière responsabilité déclare que les produits avec la Référence:
- declara bajo su propia responsabilidad, que los productos con el Número de pedido:

FRK 92/3-300 L Ex	50080724
LS 92/3 Se-L Ex	50080722
LS 92/3 E-L Ex	50080721
PRK 92/3 L Ex	50080723

Kennzeichnung Gas:

- Marking for gas:
- Certification gaz:
- Certificación gas:

 **II 2G Ex IA IIC T6**

Kennzeichnung Staub:

- Marking for dust:
- Certification poussière:
- Certificación polvo:

 **II 2D Ex IAD 21 T80°C**

Folgenden Richtlinien und Normen für die Gerätegruppe II, Gerätekategorie 2 entsprechen und bei bestimmungsgemäßer Verwendung und Beachtung der Betriebsanleitung die grundlegenden Sicherheits- und Gesundheitsanforderungen erfüllen.

- conform to the following directives and standards for equipment group II, equipment category 3. They fulfil the basic health and safety requirements if used as intended and in accordance with the operating manual.
- sont conformes aux directives et normes ci-dessous pour les appareils du groupe II, catégorie 3 et que sous réserve d'utilisation conforme et du respect des consignes du manuel d'utilisation ceux-ci répondent aux exigences fondamentales pour la sécurité et la santé.
- corresponden a las directivas y normas para grupo de aparatos II categoría de aparatos 3 y que cumplen los requerimientos de seguridad y de salud al ser empleados debidamente teniendo en cuenta las instrucciones de uso.

Richtlinie 94/9/EG / Richtlinie 89/336/EWG

- Directive 94/9/EC / Directive 89/336/EEC
- Directive 94/9/CE / Directive 89/336/CEE
- Directiva 94/9/CE / Directiva 89/336/CEE

EN 60079-0:2006

- EN 60079-11:2007**
- EN 61241-0:2006**
- EN 61241-11:2006**

Owen, den 4. März 2009

 Dr. Harald Gröbel (Geschäftsführer/ General Manager/ Directeur / Gerente)

Leuze electronic GmbH + Co. KG
 In der Braike 1
 D-73277 Owen
 Telefon +49 (0) 7021 573-0
 Telefax +49 (0) 7021 573-199
 info@leuze.de
 www.leuze.com

Leuze electronic GmbH + Co. KG, Sitz Owen, Registergericht: Stuttgart, HRB 230712
 Parallelbetrieb haftungsverbindliche Gesellschaften Leuze electronic, Geschäftsführung: Gröbel,
 Sitz Owen, Registergericht Stuttgart, HRB 230660
 Geschäftsführer: Dr. Harald Gröbel (Vorsitzender), Kirsten Just
 UStID-Nr.: DE145912521 ; Zollnummer: 2564232
 Es gelten ausschließlich unsere aktuellen Verkaufs- und Lieferbedingungen.
 Only our current Terms and Conditions of Sale and Delivery shall apply.