



LS 96

Throughbeam photoelectric sensors



Dimensioned drawing

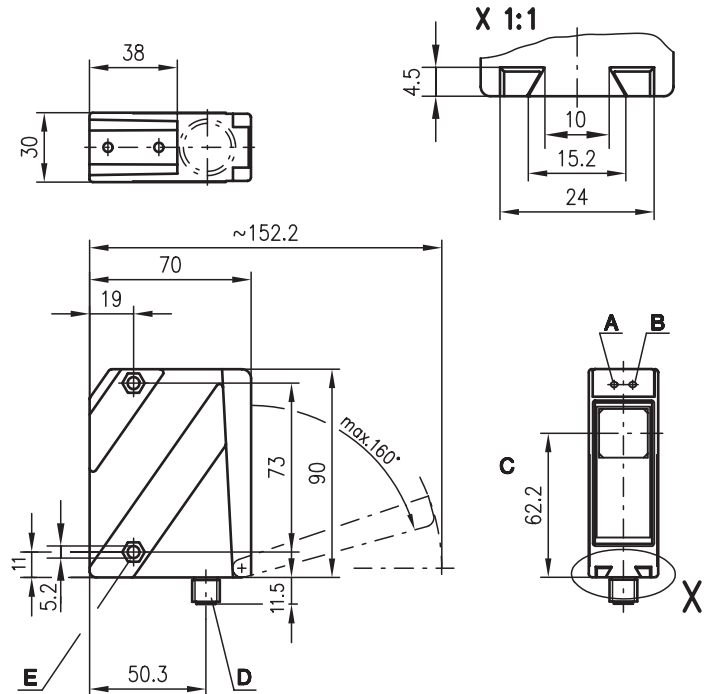

- A Indicator diode green
- B Indicator diode yellow
- C Optical axis
- D Device plug M12x1
- E Countersinking for SK nut M5, 4.2 deep



39m



- Throughbeam photoelectric sensors with high performance reserve in red light
- Robust metal housing with glass cover, protection class IP 67/IP 69K for industrial application
- Receiver with integrated AS-i slave technology
- Transmitter without integrated AS-i slave technology; receives voltage supply via AS-i line
- Wide angle version to simplify the alignment

Electrical connection

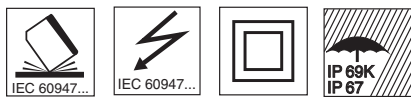
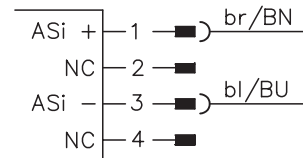

Accessories:

(available separately)

- Mounting systems (BT 96, BT 96.1, UMS 96, BT 450.1-96)
- M12 connectors
- Ready-made cables (K-D ...)
- Alignment aid ARH 96

AS-i Accessories:

(available separately)

- Bus terminals
- AS-i ribbon cable
- Address programming device
- Coupling modules, intermediate cables, etc.

We reserve the right to make changes * 96_a09e.fm

Specifications

Optical data

Typ. operating range limit ¹⁾	0 ... 39m
Operating range ²⁾	0 ... 30m
Light source	LED (modulated light)
Wavelength	660nm (red light)

Timing

Sensor switching frequency	500Hz
Sensor response time	1ms
Delay before start-up	≤ 200ms

Electrical data

Operating voltage U_B	26.5 ... 31.6V (according to AS-i specification)
Bias current receiver	≤ 35mA
Bias current transmitter	≤ 15mA

Indicators

LED green	ready
LED yellow	light path free
LED yellow flashing	light path free, no performance reserve

Mechanical data

Housing	diecast zinc
Optics cover	glass
Weight	380g
Connection type	M12 connector

Environmental data

Ambient temp. (operation/storage)	-20°C ... +60°C/-40°C ... +70°C
Protective circuit ³⁾	1, 2
VDE safety class ⁴⁾	II, all-insulated
Protection class	IP 67, IP 69K ⁵⁾
LED class	1 (acc. to EN 60825-1)
Standards applied	IEC 60947-5-2

AS-i data for receiver

I/O code	1
ID code	1
Cycle time acc. to AS-i specification	5ms
AS-i standard according to profile	S-1.1

- 1) Typ. operating range limit: max. attainable range without performance reserve
- 2) Operating range: recommended range with performance reserve
- 3) 1=transient protection, 2=polarity reversal protection
- 4) Rating voltage 250VAC
- 5) IP 69K test acc. to DIN 40050 part 9 simulated, high pressure cleaning conditions without the use of additives, acids and bases are not part of the test

Assignment: data bits				Assignment: parameter bits			
		Programming (host level)				Programming (host level)	
D ₀	Switching output	∅ no reflection 1 reflection	System input	*P ₀	NC	∅ 1	System parameter
D ₁	Warning output autoControl	∅ active 1 not active	System input	*P ₁	Light/dark switching	∅ dark switching 1 light switching	System parameter
D ₂	Ready output	∅ sensor not ready 1 sensor ready	System input	*P ₂	NC	∅ 1	System parameter
*D ₃	NC	∅ 1		*P ₃	NC	∅ 1	System parameter

* default = 1

Order guide

	Designation	Part No.
Transmitter and receiver	LS 96M/A-182W-4	
Transmitter	LSS 96 M-180W-44	500 82040
Receiver	LSE 96 M/A-182W-44	500 82039

Tables

0	30	39
---	----	----

- Operating range [m]
- Typ. operating range limit [m]

Diagrams

Typ. response behaviour

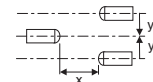
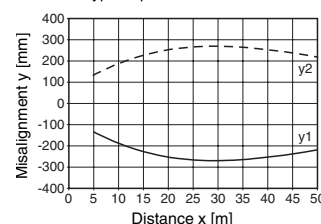

Remarks

- The transmitter has no integrated AS-i slave technology.
- The low current consumption of the transmitter enables power supply via AS-i line.
- Transmitter and receiver behave like a slave in an AS-i branch.

Angle at 3m distance:
Transmitter:
 Angle of radiation typ.: 10°
Receiver:
 Receiving angle typ.: 12°