

**HRTL 96B**

**Laser light scanner with background suppression**

Part No. 501 09888



**Dimensioned drawing**

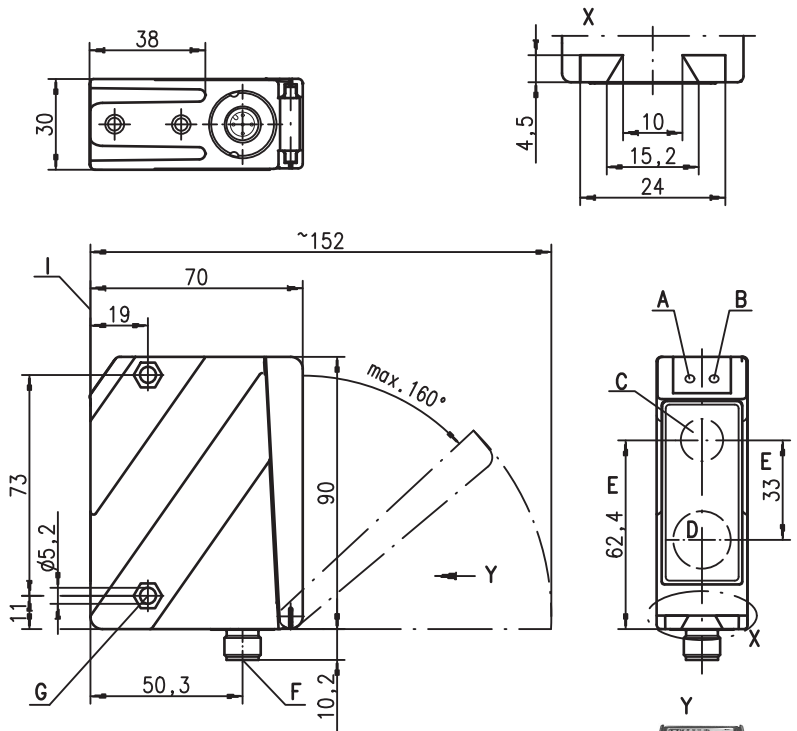

**50 ... 6,500mm**



- Laser scanner with large detection range for universal application (visible red light)
- Light propagation time measurement makes use possible under extreme environmental conditions (brightness, light, interfering contours)
- Extremely simple operation, teachable switching points
- Time lock prevents unintentional changing of the switching points
- Automatic reserve and hysteresis ensure reliable switching behaviour
- Switching behaviour independent of the direction of movement
- Optimised for positioning tasks and reliable object detection (e.g. compartment occupancy monitoring, horizontal positioning)
- Diagnostic function

- A** Green indicator diode
- B** Yellow indicator diode
- C** Transmitter
- D** Receiver
- E** Optical axis
- F** Device plug M12x1
- G** Countersinking for SK nut M5, 4.2 deep
- H** Key pad
- I** Reference edge for the measurement (cover glass)
- K** Scanning range adjustment Q1/Q2
- L** Yellow indicator diodes for switching outputs Q1/Q2

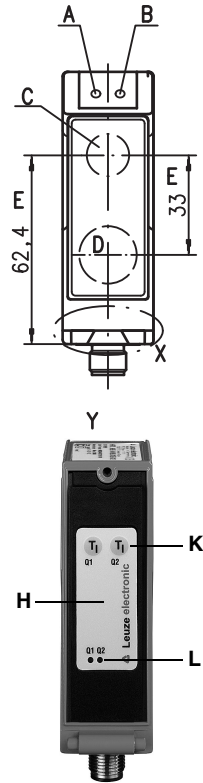

**Electrical connection**

...M/66...

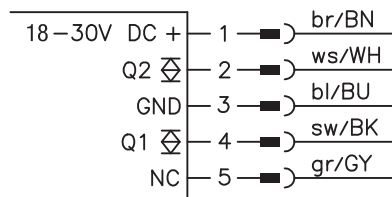

...M/V66...

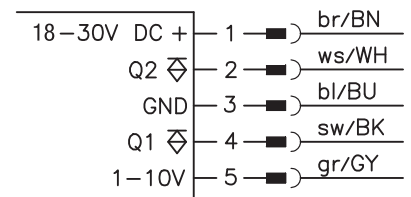

We reserve the right to make changes • 96B\_d01gb\_fm



**Accessories:**

(available separately)

- Mounting systems (BT 96, BT 96.1, UMS 96, BT 450.1-96)
- M12 connectors (KD ...)
- Ready-made cables (K-D ...)

## Specifications

### Optical data

Typ. scanning range limit (white 90%) <sup>1)</sup>	50 ... 6500mm
Scanning range <sup>2)</sup>	100 ... 6000mm
Adjustment range / teach range	150 ... 6000mm / 6 ... 90% diffuse reflection
Light source	laser (red light)
Light spot diameter	1m:6mm / 3m:5mm / 5m:4mm / 7m:4mm
Wavelength	658nm
Laser warning notice	see remarks

### Timing

Switching frequency	100Hz
Response time	5ms
Delay before start-up	≤ 200ms

### Electrical data

Operating voltage $U_B$	18 ... 30VDC (incl. residual ripple)
Residual ripple	≤ 15% of $U_B$
Open-circuit current	≤ 120mA
Switching output	.../66... 2 push-pull switching outputs <sup>3)</sup>
	PNP light switching, NPN dark switching
Analogue output	configurable: 0 ... 10V / 1 ... 10V (default) / 0 ... 5V / 1 ... 5V
Signal voltage high/low	≥ ( $U_B - 2V$ ) / ≤ 2V
Output current	max. 100mA

### Indicators

<b>Sensor front</b>	
Green LED	ready
Yellow LED	reflection ( $Q_1$ )
<b>Sensor back</b>	see table

### Mechanical data

Housing	diecast zinc
Optics cover	glass
Weight	380g
Connection type	M12 connector, 5-pin

### Environmental data

Ambient temp. (operation/storage)	-30°C ... +50°C / -35°C ... +70°C
Protective circuit <sup>4)</sup>	1, 2, 3, 4
VDE safety class <sup>5)</sup>	II, all-insulated
Protection class	IP 67, IP 69K <sup>6)</sup>
Standards applied	IEC 60947-5-2

- 1) Typ. scanning range limit: max. attainable range without performance reserve
- 2) Scanning range: recommended range with performance reserve
- 3) The push-pull switching outputs must not be connected in parallel
- 4) 1=transient protection, 2=polarity reversal protection, 3=short circuit protection for all outputs, 4=interference blanking
- 5) Rating voltage 250VAC
- 6) IP 69K test acc. to DIN 40050 part 9 simulated, high pressure cleaning conditions without the use of additives, acids and bases are not part of the test

### ● Approved purpose:

The diffuse reflection light scanners are optoelectronic sensors for optical, contactless detection of objects.

## Order guide

Selection table		Order code →		
Equipment ↓		HRTL 96BM/66.01S-S12 Part No. 501 08889	HRTL 96BM/66.02S-S12 Part No. 501 10728	HRTL 96BM/66.01S-S12 Part No. 501 10952
Housing	metal	●	●	●
Light source	red light/laser	●	●	●
Connection	M12 connector, 5-pin	●	●	●
Outputs	3 switching points			
	2 switching points	●	●	●
	2 x push-pull, PNP light switching	●	●	●
	2 x push-pull, PNP dark switching			
	teachable switching points	●	●	●
	analogue / voltage (range = 100 ... 1500)			●
	analogue / voltage (range = 100 ... 6000)			●

## Tables

Switching points	no reflection	object detected
Yellow LED Q1	off	on
Yellow LED Q2	off	on

## Diagrams

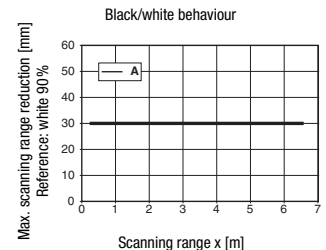

A 6 ... 90% diffuse reflection

## Remarks

- Setting switching points: Align sensor with object, press respective teach button for at least 2s, then release the button. Object is detected if the corresponding Q1/Q2 indicator illuminates.
- Reserve: For the reliable detection of objects with low reflectance, a reserve is automatically added during the teach event. This is constant over the entire teach range. Object is detected: distance to sensor ≤ teach point + reserve
- Hysteresis: To ensure continuous object detection in the switching point, the sensor has a switch-off hysteresis. Object is no longer detected if: distance to sensor > teach point + reserve + hysteresis.
- Factory setting: reserve: approx. 50mm hysteresis: approx. 50mm
- Object detection: resolution < 5mm, standard deviation ±10mm at ±3 Sigma
- Edge detection/horizontal positioning: repeatability < 1mm
- With the set scanning range, a tolerance of the upper scanning range limit is possible depending on the reflection properties of the material surface.
- Scanning range/reflectivity:

Object/diffuse reflection	
6 ... 90%	0.15 ... 6m (standard)

LASER LIGHT DO NOT STARE INTO BEAM	
Maximum Output:	1.8mW
Pulse duration:	0.5µs
Wavelength:	670nm
CLASS 2 LASER PRODUCT EN60825-1:2003-10	