

**LSL 318**

**Laser throughbeam photoelectric sensors**

**Dimensioned drawing**

en 06-2011/01 50108665

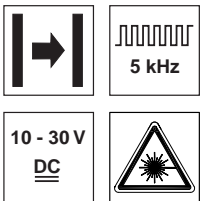

0 ... 18m  
0 ... 120m

- Throughbeam photoelectric sensors with long operating range in red laser light and straight optics
- Robust cylindrical stainless steel housing M18x1, protection class IP 67 for industrial application
- Fixed beam geometry, convergent
- High switching frequency
- Activation input for testing and interlinking of the sensor
- Complementary switching outputs for light/dark switching or as a control function
- Very short construction for application in limited spaces

LSL 318M/...

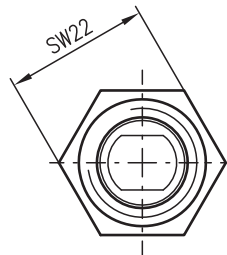
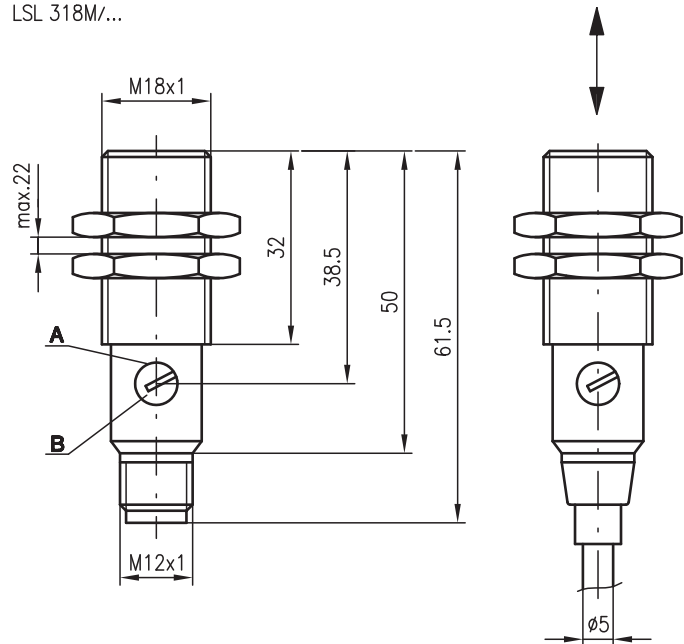

- A** Indicator diode
- B** Sensitivity adjustment

**Electrical connection**

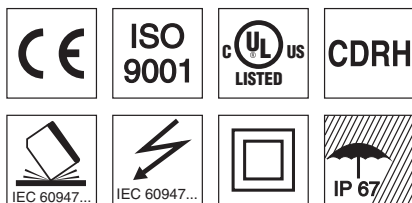
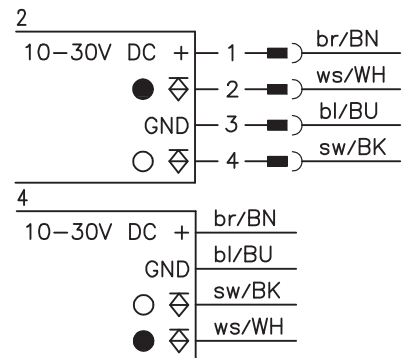
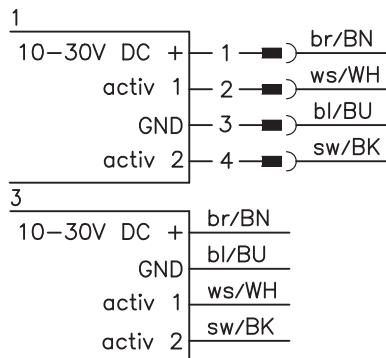

**Accessories:**

(available separately)

- Mounting systems (BT 318, BT 318-ARH)
- M12 connectors (KD ...)
- Ready-made cables (K-D ...)

We reserve the right to make changes • DS\_LSL318\_en.fm

## Specifications

### Optical data

Typ. operating range limit <sup>1)</sup>	0 ... 18m, 0 ... 120m
Operating range <sup>2)</sup>	0 ... 15m, 0 ... 100m
Light spot diameter	see diagrams
Light source	laser
Wavelength	650nm (visible red light)
Impulse duration	2µs
Max. power	0.3mW

### Timing

Switching frequency	5000Hz
Response time	0.1ms
Delay before start-up	≤ 30ms

### Electrical data

Operating voltage $U_B$ <sup>3)</sup>	10 ... 30VDC
Residual ripple	≤ 10% of $U_B$
Open-circuit current	≤ 30mA
Switching output	2 transistor outputs, complementary
Function characteristics	light/dark switching
Signal voltage high/low	≥ ( $U_B - 1.6V$ ) / ≤ 1.6V
Output current	max. 100mA
Sensitivity	adjustable (transmitter)

### Indicators

Red LED	light path free
LED red flashing	light path free, no performance reserve

### Mechanical data

Housing	stainless steel
Optics cover	polyamide 12
Weight	90g (cable), 20g (M12)
Connection type	M12 connector, 4-pin cable 2m, 4x0.25mm <sup>2</sup>

### Environmental data

Ambient temp. (operation/storage)	-25°C ... +60°C / -40°C ... +70°C
Protective circuit <sup>4)</sup>	1, 2, 3, 4
VDE safety class <sup>5)</sup>	II, all-insulated
Protection class	IP 67
Laser class	1 (according to EN 60825-1 and 21 CFR 1040.10 with Laser Notice No. 50)
Standards applied	IEC 60947-5-2, UL 508

### Options

<b>Activation input active 1</b>	≥ 8V or not connected / ≤ 1.5V
<b>Activation input active 2</b>	≤ 1.5V or not connected / ≥ 8V

- 1) Typ. operating range limit: max. attainable range without performance reserve
- 2) Operating range: recommended range with performance reserve
- 3) For UL applications: for use in class 2 circuits according to NEC only
- 4) 1=transient protection, 2=polarity reversal protection, 3=short circuit protection for all outputs, 4=interference blanking
- 5) Rating voltage 250VAC

## Order guide

Selection table		Order code →			
Equipment ↓		LSL 318M/P-S12 Part no. 500 83172 (Tr) Part no. 500 83176 (Re)	LSL 318M/P-B5-S12 Part no. 500 83172 (Tr) Part no. 500 83180 (Re)	LSL 318M/P Part no. 500 83171 (Tr) Part no. 500 83175 (Re)	LSL 318M/P-B5 Part no. 500 83171 (Tr) Part no. 500 83179 (Re)
Housing	Stainless steel	●	●	●	●
Connection	M12 connector	●	●		
	Cable			●	●
Switching output	PNP	●	●	●	●
	NPN				
Operating range	15m		●		●
	100m	●		●	
Connection diagram	Transmitter	1	1	3	3
	Receiver	2	2	4	4

## Tables

LSL 318...		
0	100	120

LSL 318...-B5...		
0	15	18

□	Operating range [m]
■	Typ. operating range limit [m]

Versions LSL 318...-B5... : with integrated optical pin diaphragm Ø 1.0mm for the detection of small parts or precise positioning tasks.

## Diagrams

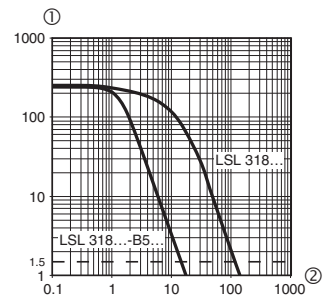
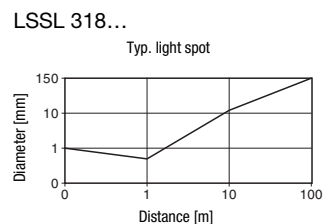

Typical behaviour operating range / relative intensity of received light

- 1 Relative intensity of received light
- 2 Operating range in [m]

## Remarks

### Approved purpose:

This product may only be used by qualified personnel and must only be used for the approved purpose. This sensor is not a safety sensor and is not to be used for the protection of persons.