

GSL 04

Laser forked photoelectric sensors

Dimensioned drawing

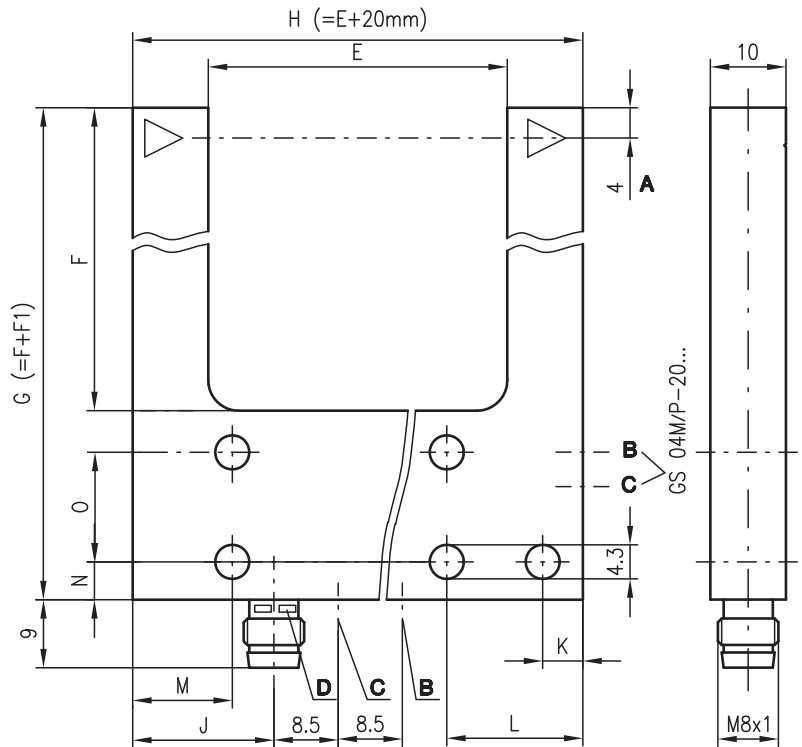

- A** Optical axis
- B** Sensitivity adjustment
- C** Light/dark switching
- D** Indicator diode

	E Mw	F Mt	F1	G	H	J	K	L	M	N	O
GSL 04M/...-30...	30	34	25	59	50	12	4.5	12.5	4.5	4.5	-
GSL 04M/...-50...	50	54	25	79	70	12	4.5	12.5	4.5	4.5	-
GSL 04M/...-80...	80	54	25	79	100	12	4.5	12.5	4.5	4.5	-

Electrical connection

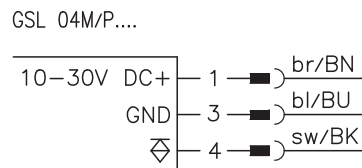

en 05-2010/11 50110847

30/50/80/120mm

10 - 30 V DC
5 kHz

- Laser-generated red light for high-precision applications
- Sensitivity adjustment and light/dark switching for optimal adaptation to the application
- Sensitivity adjustment on the back of the fork
- Robust metal housing and glass optics for protection against environmental influences
- Detection of transparent objects
- Laser class 1

CE ISO 9001 IP 67

IEC 60947... IEC 60947... c UL US LISTED CDRH

Accessories:

(available separately)

- M8 connectors (KD ...)
- Cable with M8 connector (K-D...)

We reserve the right to make changes • DS_GSL_04_M_P_en.fm

Specifications

Optical data

Mouth width	30/50/80/120mm
Light source	laser, pulsed
Wavelength	650nm red light

Timing

Switching frequency	5000Hz
Response time	0.1ms
Delay before start-up	≤ 100ms

Electrical data

Operating voltage U_B ^{1) 2)}	10 ... 30VDC (incl. residual ripple)
Residual ripple	≤ 15% of U_B
Open-circuit current	≤ 35mA
Switching output	PNP transistor output
Function characteristics	light/dark switching reversible
Signal voltage high/low	≥ ($U_B - 2V$) / ≤ 2V
Output current	200mA
Sensitivity	adjustable (potentiometer, adjustment range 0 ... 270°)

Indicators

Red LED	state of switching output
---------	---------------------------

Mechanical data

Housing	diecast zinc
Weight	see order guide
Optics cover	glass
Connection type	M8 connector, 3-pin

Environmental data

Ambient temp. (operation/storage)	-10°C ... +60°C / -20°C ... +70°C
Protective circuit ³⁾	1, 2
VDE safety class	III
Protection class	IP 67
Laser class	1 (acc. to EN 60825-1)
Certifications	UL 508 ⁴⁾ , CDRH 21, CFR 1040

- 1) Functional extra-low voltage with reliable disconnection or protective extra-low voltage (VDE 0100/T 410)
- 2) Observe the safety regulations and installation instructions regarding power supply and wiring
- 3) 1=polarity reversal protection, 2=short-circuit protection for all outputs
- 4) For UL applications: for use in class 2 circuits according to NEC only

Mouth width [mm]	Smallest detectable object [mm]	Reproducibility [µm]	Switching hysteresis [µm]
30	0.05	10	≤ 20
50	0.08	10	≤ 25
80	0.10	10	≤ 30

Order guide

Selection table				
Order code →	GSL 04M/P-30-S8 Part No. 501 10793	GSL 04M/P-50-S8 Part No. 501 10794	GSL 04M/P-80-S8 Part No. 501 10795	GSL 04M/P-80-4-S8 Part No. 501 11362
Equipment ↓				
Mouth width [mm]	30	50	80	80
Weight in g	36	54	77	77
For transparent objects				●

Tables

Diagrams

Remarks

Approved purpose:

This product may only be used by qualified personnel and must only be used for the approved purpose. This sensor is not a safety sensor and is not to be used for the protection of persons.