

IGSU 14B SD

Splice sensor

en 01-2011/06 50116166



Dimensioned drawing

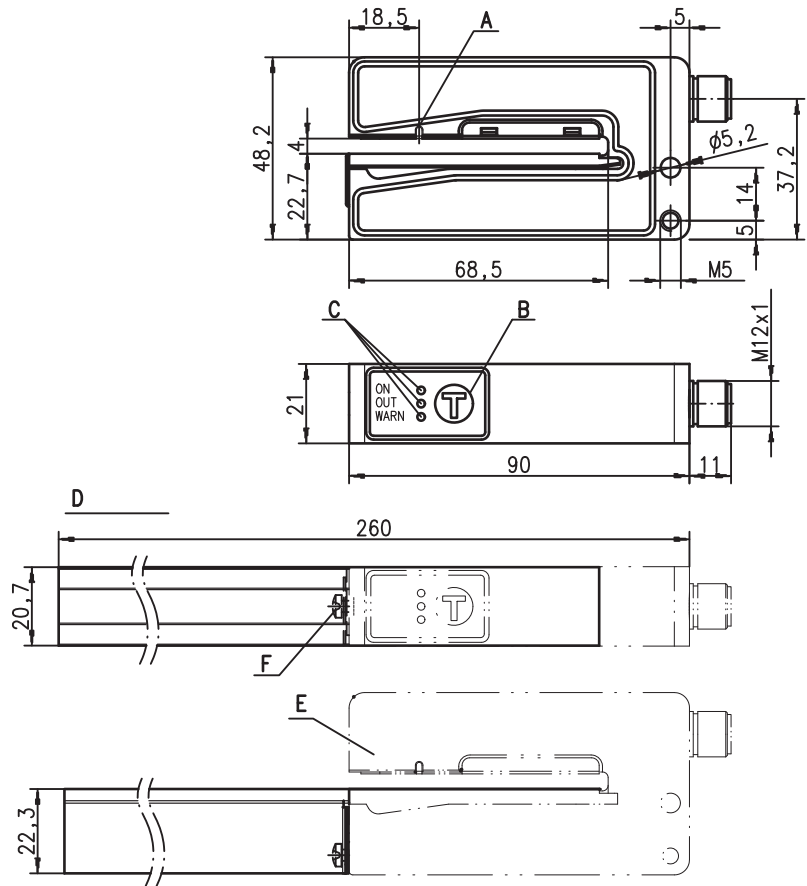

- A Sensor marker
- B Teach-in button
- C Indicator diodes (ON, OUT, WARN)
- D View with extended carriage mounted
- E Sensor
- F Fastening screw for carriage



4mm



- Reliable detection of splice on paper web or plastic web
- With integrated paper tear monitoring
- Simple teach process on sheet with or without splice transport
- Switching signal with pulse stretching (can be switched off)
- Warning output for indicating teach errors or paper tear
- Easy adjustment via lockable teach button or teach input

Electrical connection

IGSU 14B/6.3 SD-S12

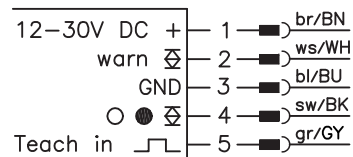

UL approval applied for



Accessories:

(available separately)

- Carriage short (Part No. 50114055)  
As replacement for the series part.
- Extended carriage (Part No. 50114056)  
For better guiding of oversized labels.  
The rail can be shortened at any point.
- M12 connectors (KD ...)
- Cable with M12 connector (K-D...)

We reserve the right to make changes • DS\_IGSU\_14B\_SD\_en.fm

## Specifications

### Physical data

Mouth width	4 mm
Mouth depth	68 mm
Web speed <sup>1)</sup>	≤ 2400m/min (≤ 40m/s) at 10mm splice width
Web speed with teach-in	≤ 50m/min (≤ 0.83m/s)
Response time	≤ 250 μs
Delay before start-up	≤ 300ms acc. to IEC 60947-5-2

### Electrical data

Operating voltage $U_B$	12VDC (-5%) ... 30VDC (incl. residual ripple)
Residual ripple	≤ 15% of $U_B$
Open-circuit current	≤ 80mA
Switching output <sup>2)</sup>	.../6 pin 4: push-pull switching output PNP transistor: ON if splice is detected, NPN transistor: ON if paper is detected
Warning output <sup>2)</sup>	pin 2: push-pull switching output active low (normal operation high, event case low)
Function switching output IGSU	splice detected
Pulse stretching <sup>3)</sup>	20ms
Signal voltage high/low	≥ ( $U_B - 2V$ ) / ≤ 2V
Output current	≤ 100mA
Capacitive load	≤ 0.5μF

### Indicators

Green LED	ready
Yellow and green LEDs flash	teach-in activated
Yellow LED	splice detected
Red LED	teaching error / function error / paper tear
LED red flashing	short-circuit switching / warning output

### Mechanical data

Housing	aluminum, anodized
Color	red/black
Weight	160g
Connection type	M 12 connector, 5-pin

### Environmental data

Ambient temp. (operation/storage)	0°C ... +60°C / -40°C ... +70°C
Protective circuit <sup>4)</sup>	1, 2
VDE safety class	III
Protection class	IP 65
Standards applied	IEC 60947-5-2

### Options

#### Teach-in input

Active/not active	≥ 8V / ≤ 2V
Input resistance	15kΩ

- 1) Dependent on material  
 2) The push-pull switching outputs must not be connected in parallel  
 3) Can be switched off  
 4) 1=polarity reversal protection, 2=short-circuit protection for all outputs

## Order guide

### Ultrasonic sensor for splice inspection

With 2 x push-pull outputs:  
 Pin 4: signal at splice, pin 2: warning output;  
 Teach-in via button on device and teach input;  
 Connection: M12 connector

Designation	Part No.
IGSU 14B/6.3 SD-S12	50115736

## Tables

## Diagrams

Splice width in dependence of web speed

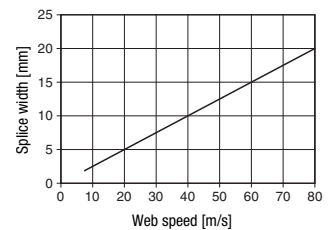

## Remarks

### Approved purpose:

This product may only be used by qualified personnel and must only be used for the approved purpose. This sensor is not a safety sensor and is not to be used for the protection of persons.

- To achieve reliable splice detection, the sheet must be slightly under tension on the carriage (B).

Overview of operating structure for IGSU 14B

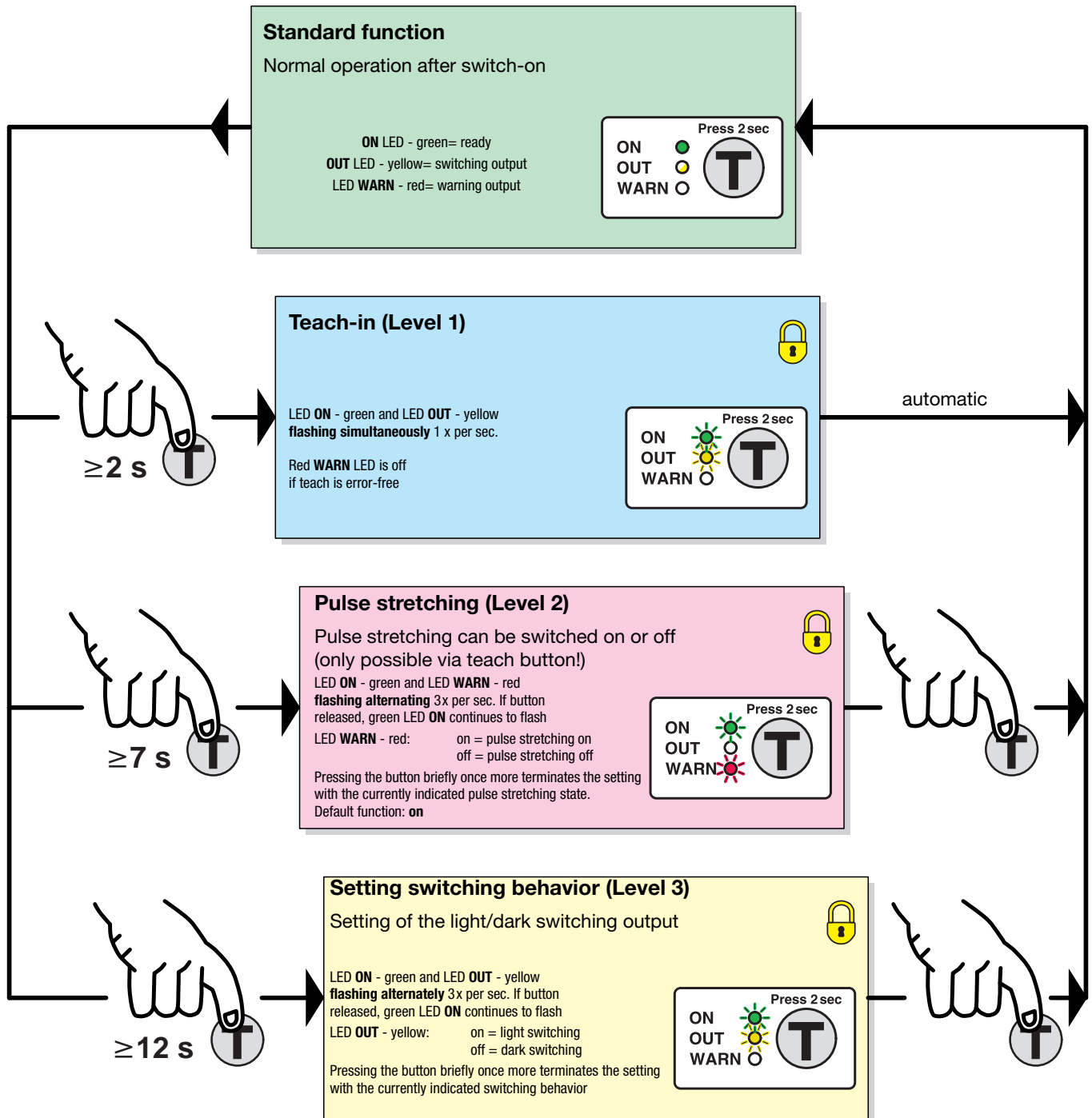

= function lockable through constant application of U<sub>B</sub> on the teach input

## Sensor adjustment (teach-in) via teach button

### easy Teach with or without foil web transport

Preparation: Insert sheet into the sensor.

- Press the teach button until green and yellow LEDs flash simultaneously.
- Release teach button - the green and yellow LEDs flash simultaneously and faster. The teach time of approx. 6s begins.
- If the sheet is not transported, it remains unchanged and slightly under tension in the sensor. Alternatively, the sheet can be transported through the sensor with a max. speed of 50m/min. If no splice is transported through the sensor, the sensor calculates the switching threshold as a function of this state.  
Advantage: very simple execution.
- If a splice is transported through the sensor during teach time, the sensor calculates the switching threshold as a function of both states. Advantage: very reliable detection.
- After the teach time is over, the sensor automatically ends the teach event.

If the teach process is faulty (e.g. unfavorable material combination), the red LED lights and the warning output is activated. Repeat the teach process. If the fault cannot be rectified, the sheet material cannot be detected with the IGSU 14B.

When changing to another type of sheet, a new adjustment should generally be carried out by carrying out a new teach-in event.

### Setting the pulse stretching

- Press the teach button until green and red LEDs flash alternately.
- Release the teach button - the green LED continues to flash, the red LED alternates slowly between ON and OFF.
- Red LED ON = pulse stretching on  
Red LED off = pulse stretching off.
- Pressing the button briefly once more terminates the setting with the currently indicated pulse stretching state.
- Finished.

**Attention:** This function can only be executed with the teach button!

### **Pulse stretching (20ms):**

If the web speed is high and the splice width is thin, the signal on the switching output is very short when moving over a splice. Therefore pulse stretching (set to 20ms) is activated in the factory settings. If this is undesirable, the function can be switched off as described above.

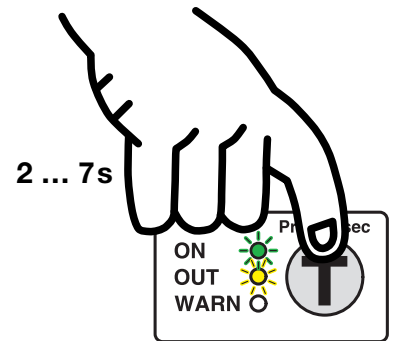
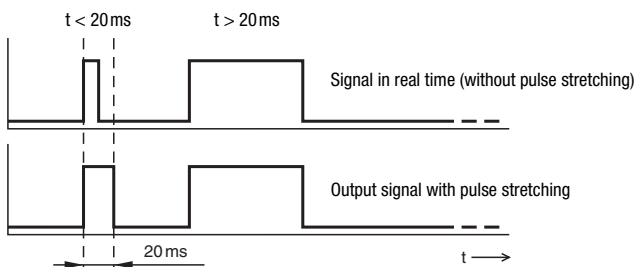

The **green** and the **yellow** LEDs flash **simultaneously** approx. **1x** per sec.

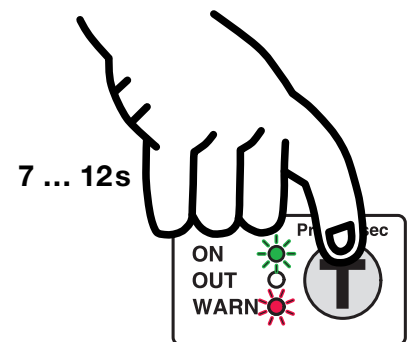

The **green** and the **red** LEDs flash **alternately** approx. **3x** per sec.

**Warning output and red LED on sensor**

Function characteristics	Red LED on sensor	Warning output (Pin 2)	Explanation and measures
Paper tear	LED ON	Active: low	Paper tear: -> check sheet.
Teach error	LED ON	Active: low	Material outside of working range (too thin or too thick): -> with use of too-thick material, check the use of Leuze VSU 12.
Subvoltage	LED ON	No change	-> check supply voltage.
Short-circuit or overload on an output	LED flashes	Tri-state <sup>1)</sup>	-> check connections, -> remedy short-circuit or overload.

1) The output on the sensor is high-impedance in tri-state mode. Depending on the input wiring of the downstream control electronics, the signal is **low** in the case of input wiring with pull-down resistor or **high** in the case of wiring with a pull-up resistor.

**Adjusting the switching behavior of the switching output (light/dark switching)**

- Press the teach button until green and yellow LEDs flash **alternately**.
- Release the teach button - the green LED continues to flash, the yellow LED alternates slowly between ON and OFF.
- Yellow LED ON = output switches on light  
Yellow LED OFF = output switches on dark.
- Pressing the button briefly once more terminates the setting with the currently indicated switching behavior.
- Finished.

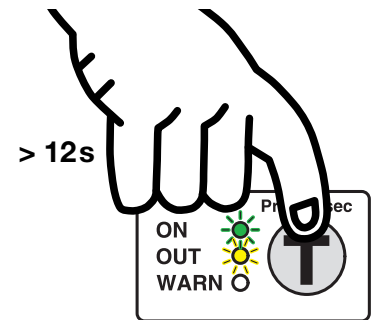

The **green** and the **yellow** LEDs flash alternately approx. **3x** per sec.

**Sensor adjustment (teach-in) via teach input**



The following description applies to PNP switching logic!

$U_{Teach}$	Not connected	Internal pull-down resistor pulls the input down to zero	Teach button can be operated; all functions adjustable
$U_{Teach\ low}$	$\leq 2V$	Low level	Teach button can be operated; all functions adjustable
$U_{Teach\ high}$	$\geq (U_B - 2V)$	High level	Teach button disabled; button has no function
$U_{Teach}$	$> 2V \dots < (U_B - 2V)$	Not permitted	Level not defined; current state is retained

The device setting is stored in a fail-safe way. A reconfiguration following voltage interruption or switch-off is thus not required.

**easyTeach with or without foil web transport**

Preparation: Insert sheet into the sensor.

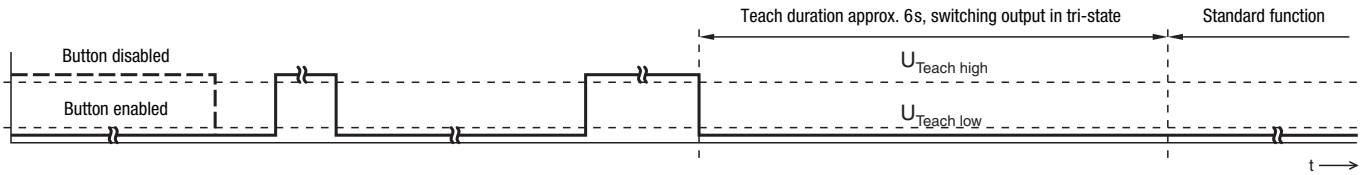

After switching on the supply voltage and after the delay before start-up has concluded ( $\leq 300$ ms), the teach button on the device can be operated.	2 x	<b>easyTeach:</b> $t_{Teach} = 4 \dots 900$ ms	4 ... 100ms	Teach event starts: the green and yellow LEDs flash simultaneously for approx. 1x a second. If the sheet is not transported, it remains unchanged and slightly under tension in the sensor. Alternatively, the sheet can be transported through the sensor with a max. speed of 50 m/min. If no splice is transported through the sensor, the sensor calculates the switching threshold as a function of this state.  Advantage: very simple execution.  If a splice is transported through the sensor during teach time, the sensor calculates the switching threshold as a function of both states.  Advantage: very reliable detection.  During the event, the button on the device is disabled, it can be operated again after this.	
	4 ... 100ms				
	Only if the teach button was disabled before the teach.				
	The teach button is disabled after the 1st edge transition.				

When a teach error occurs (e.g. sheet cannot be reliably detected due to insufficient signals), the red LED flashes. Independent of the state, the green LED switches on when the teach event has ended, and the yellow LED displays the current switching state.

**Adjusting the switching behavior of the switching output – light/dark switching**

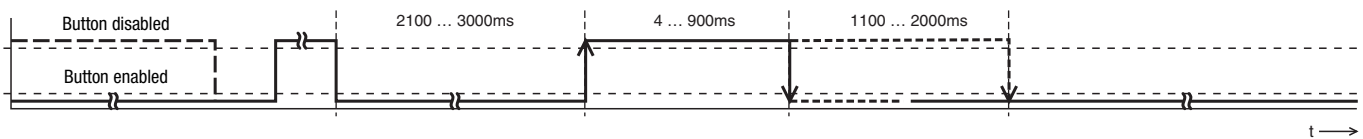

After switching on the supply voltage and after the delay before start-up has concluded ( $\leq 300$ ms), the teach button on the device can be operated.	2 x	<b>Teach switching output:</b> $t_{Teach} = 2100 \dots 3000$ ms	Switching output light switching (4 ... 900ms) Switching output dark switching (1100 ... 2000ms)	The teach button is enabled again.
	4 ... 100ms			
	The teach button is disabled after the 1st edge transition.			
	The teach button is disabled after the 1st edge transition.			

**Locking the teach button via the teach input**



**IGSU 14B:**

A static high signal ( $\geq 4$  ms) on the teach input locks the teach button on the device if required so that no manual operation is possible (e.g. protection against erroneous operation or manipulation).

If the teach input is not connected or if there is a static low signal, the button is enabled and can be operated freely.

