

ODSL 8

Optical laser distance sensors

Art. No. 501 09346



Dimensioned drawing

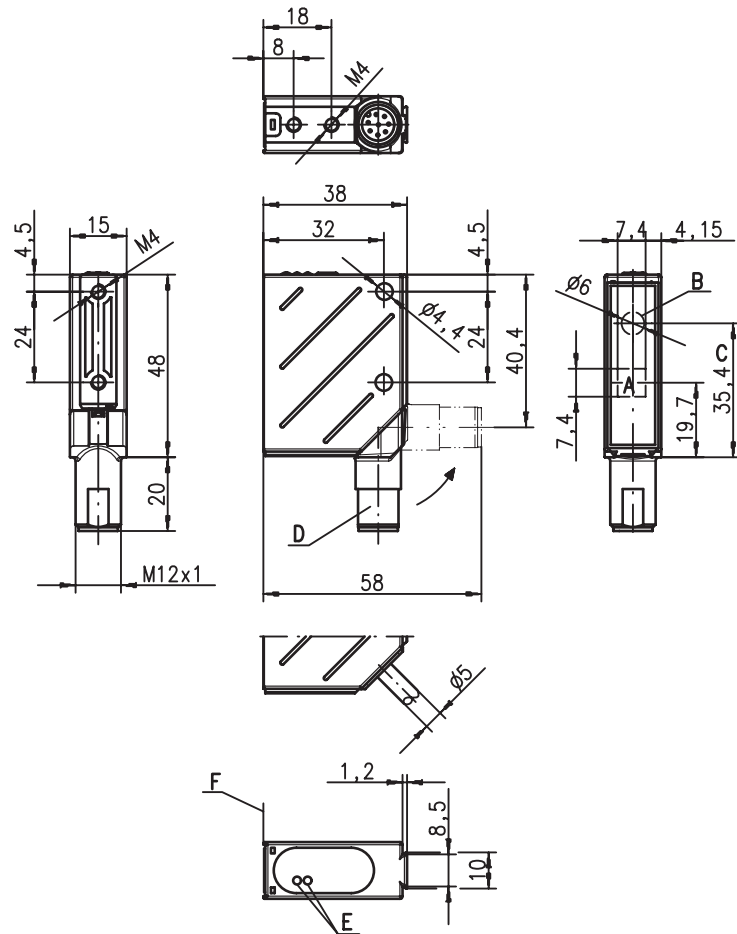

- A Receiver
- B Transmitter
- C Optical axis
- D 90° turning connector
- E LED yellow, green
- F Reference edge for the measurement (cover glass)

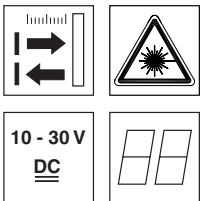

25 ... 45 mm

- Reflection-independent distance information
- Highly insensitive to extraneous light
- Digital RS 232 and RS 485 interface
- Measurement range and mode adjustable
- Teachable switching output
- M 12 turning connector

Electrical connection

10-30V DC +	1	ws/WH
RxD RS232	2	br/BN
GND	3	gn/GN
1.	4	ge/YE
teach in	5	gr/GR
TxD RS232	6	rs/PK
Tx+ RS485	7	bl/BU
TX- RS485	8	rt/RD



Accessories:

(available separately)

- Mounting systems
- Cable with M12 connector (K-D ...)
- Configuration software
- Control guard

We reserve the right to make changes • ods_22gb.fm

Specifications

Optical data

Measurement range ¹⁾	25 ... 45mm
Resolution	0.01 mm
Light source	laser
Wavelength	650nm (visible red light)
Light spot	divergent, 1x6mm ² at 45mm
Laser warning notice	see remarks

Error limits (relative to measurement distance)

Absolute measurement accuracy ¹⁾	0.5%
Repeatability ²⁾	0.1%
b/w detection thresh. (6 ... 90% rem.)	≤ 0.5%

Timing

Measurement time	2 ... 5ms
Response time	≤ 15ms
Delay before start-up	≤ 300ms

Electrical data

Operating voltage U _B	10 ... 30VDC (incl. residual ripple)
Residual ripple	≤ 15% of U _B
Open-circuit current	≤ 50mA
Switching output	PNP transistor, high-active
Signal voltage high/low	≥ (U _B -2 V)/≤ 2V
Digital output RS 232	9600 Baud
RS 485	9600 Baud, no termination
Transmission protocol ³⁾	2 byte transmission, continuous data flow

Indicators

LED green	continuous light	ready	
	flashing	fault	teaching procedure
	off	no voltage	
Yellow LED	continuous light	object inside teach-in measurement distance	
	flashing		teaching procedure
	off	object outside teach-in measurement distance	

Mechanical data

Housing	metal
Optics cover	glass
Weight	70g
Connection type	M12 connector, 8-pin, turning

Environmental data

Ambient temp. (operation/storage)	-20°C ... +50°C/-40°C ... +70°C
Protective circuit ⁴⁾	1, 2, 3
VDE safety class ⁵⁾	II, all-insulated
Protection class ⁶⁾	IP 67, IP 69K ⁷⁾
Laser class	2 (acc. to EN 60825-1)
Standards applied	IEC 60947-5-2

- 1) Luminosity coefficient 6% ... 90%, over the entire temperature range, measurement object ≥ 50x50mm²
- 2) Same object, identical environmental conditions, measurement object ≥ 50x50mm²
- 3) 2byte transmission protocol
- 4) 1=transient protection, 2=polarity reversal protection, 3=short circuit protection for all outputs
- 5) Rating voltage 250VAC
- 6) In stop position of the turning connector (turning connector locked)
- 7) IP 69K test acc. to DIN 40050 part 9 simulated, high pressure cleaning conditions without the use of additives, acids and bases are not part of the test

Measurement value = 14 Bit

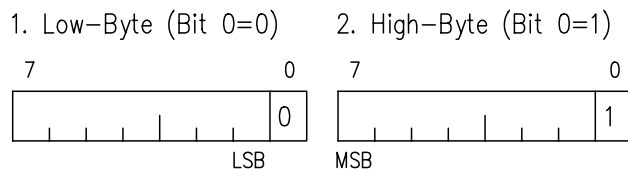

Order guide

With M12 connector

Designation

ODSL 8/D4-45-S12 501 01884

Tables

Diagrams

Remarks

- Configuration via PC
 - Connect the device to voltage and simultaneously apply +24VDC to teach-in (PIN 5)
 - Connect RS 232 directly to the PC
 - Start ODS 96 configuration software, password "ODS_96"
- Measurement time depends on the reflectivity of the measurement object and on the measurement mode.
- Teaching procedure: Position measured object at desired measurement distance. Connect teach input to +U_B for ≥ 2s. Reconnect teach input to GND, switching output is programmed.
- Approved purpose: The ODSL 8 laser distance sensors are optical electronic sensors for the optical, contactless measurement of distance to objects.

