

ODSL 96B

Optical laser distance sensors

Art. Nr. 501 08382



Dimensioned drawing

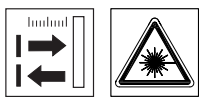
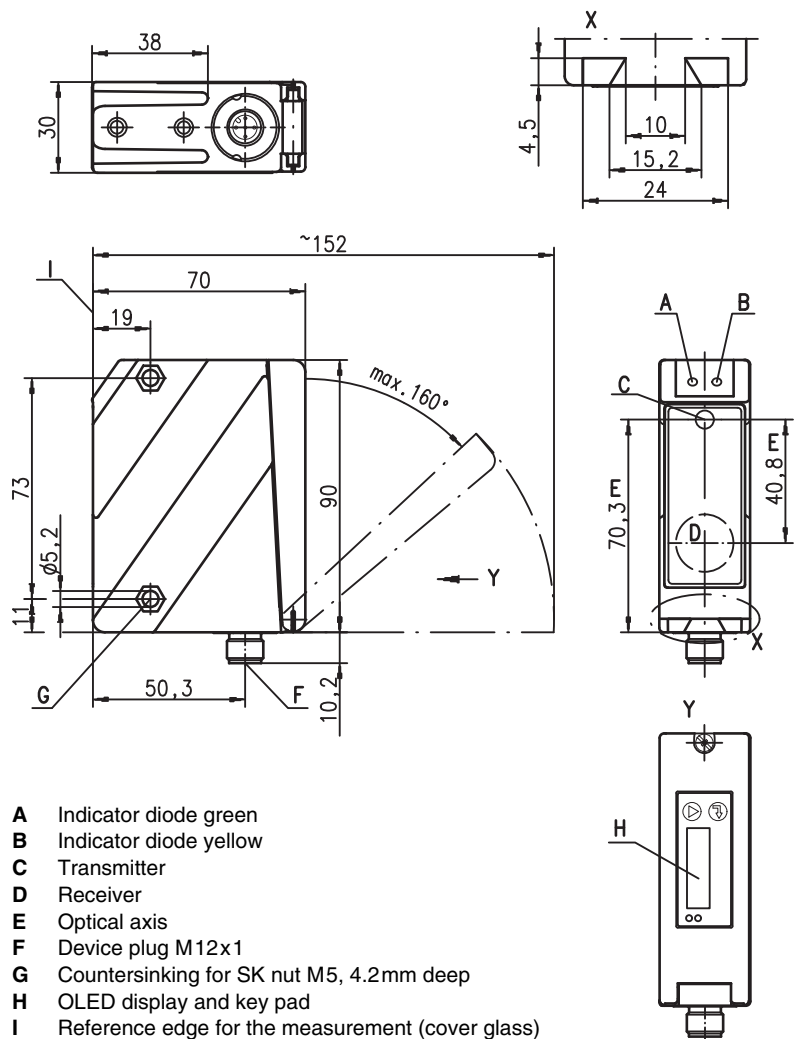

150 ... 2000 mm

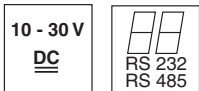

- Reflection-independent distance information
- Highly insensitive to extraneous light
- RS 232 or RS 485 interface
- Measurement transmission configurable (14 bit, 16 bit, ASCII, remote operation)
- Baud rate 9600 ... 57600Bd
- PC/OLED display and key pad for configuration
- Measurement value is indicated in mm on OLED display
- Measurement mode configurable

Electrical connection

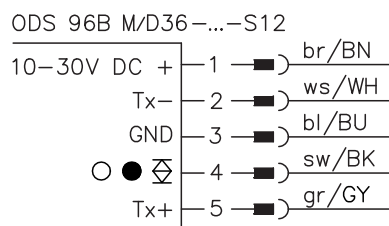
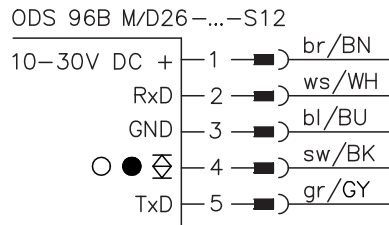

Accessories:

(available separately)

- Mounting systems
- Cable with M12 connector (K-D ...)
- Configuration software

We reserve the right to make changes • ods_47gb.fm

Specifications

Optical data

Measurement range ¹⁾	150 ... 2000mm
Resolution ²⁾	1 ... 3mm
Light source	laser
Wavelength	655nm (visible red light)
Light spot	divergent, 2x6mm ² at 2m
Laser warning notice	see remarks

Error limits (relative to measurement distance)

Absolute measurement accuracy ¹⁾	± 1.5%
Repeatability ³⁾	± 0.5%
b/w detect. thresholds (6 ... 90% rem.)	≤ 1%
Temperature compensation	yes ⁴⁾

Timing

Measurement time	1 ... 5 ¹⁾ ms
Response time ¹⁾	≤ 15ms
Delay before start-up	≤ 300ms

Electrical data

Operating voltage U _B ⁵⁾	10 ... 30VDC (incl. residual ripple)
Residual ripple	≤ 15% of U _B
Open-circuit current	≤ 150mA
Switching output	push-pull switching output ⁶⁾ , PNP light switching, NPN dark switching
Signal voltage high/low	≥ (U _B -2 V)/≤ 2V
Serial interface	RS 232/RS 485, 9600 ... 57600Bd, 1 start bit, 8 data bits, 1 stop bit, no parity
Transmission protocol	14 bit, 16 bit, ASCII, Remote Control

Indicators

	teach-in on GND	teach-in on +U_B
Green LED	continuous light ready	
	flashing fault	teaching procedure
	off no voltage	
Yellow LED	continuous light object inside teach-in measurement distance	teaching procedure
	flashing object outside teach-in measurement distance	
	off	

Mechanical data

Housing	diecast zinc
Optics cover	glass
Weight	380g
Connection type	M12 connector

Environmental data

Ambient temp. (operation/storage)	-20°C ... +50°C / -30°C ... +70°C
Protective circuit ⁷⁾	1, 2, 3
VDE safety class ⁸⁾	II, all-insulated
Protection class	IP 67, IP 69K ⁹⁾
LED class	1 (acc. to EN 60825-1)
Standards applied	IEC 60947-5-2

- 1) Reflectivity 6% ... 90%, complete measurement range, at 20°C, medium range U_B, measurement object ≥ 50x50mm², depending on the measurement transmission type and the baud rate
- 2) Minimum and maximum value depend on measurement distance
- 3) Same object, identical environmental conditions, measurement object ≥ 50x50mm²
- 4) Typ. ± 0.02 %/K
- 5) For UL applications: for use in class 2 circuits according to NEC only
- 6) The push-pull switching outputs must not be connected in parallel
- 7) 1=transient protection, 2=polarity reversal protection, 3=short circuit protection for all outputs
- 8) Rating voltage 250VAC, with cover closed
- 9) IP 69K test acc. to DIN 40050 part 9 simulated, high pressure cleaning conditions without the use of additives. Acids and bases are not part of the test.

Transmission protocol

Factory setting: 9600Bd, 1 start bit, 8 data bits, 1 stop bit, transmission protocol ASCII measurement value

Transmission format: **MMMMM<CR>**

MMMMM = measurement value 5 digits in mm (resolution 1 mm)

<CR> = ASCII character "Carriage Return" (x0D)

 Further information about available transmission protocols may be found in the technical description "Optical distance sensors ODS 96B".

Order guide

	Designation	Part No.
With M12 connector		
RS 232 interface	ODSL 96B M/D26-2000-S12	501 06597
RS 485 interface	ODSL 96B M/D36-2000-S12	501 06598

Tables

Diagrams

Remarks

- Measurement time depends on the reflectivity of the measurement object and on the measurement mode.

LASER LIGHT DO NOT STARE INTO BEAM	
Maximum Output:	1.2mW
Pulse duration:	22ms
Wavelength:	655nm
CLASS 2 LASER PRODUCT EN60825-1:2003-10	

LASER LIGHT DO NOT STARE INTO BEAM	
Maximum Output:	1.2mW
Pulse duration:	22ms
Wavelength:	655nm
CLASS 2 LASER PRODUCT IEC 60825-1:1993+A2:2001 Complies with 21 CFR 1040.10	

- **Approved purpose:**
The ODSL 96B distance sensors are optical electronic sensors for the optical, contactless measurement of distance to objects.